

Martin Fischer and Peter Röben (Eds.)

# **Cases of Organisational Learning in European Chemical Companies**

**An empirical study**

**Second edition**

**ITB - Arbeitspapiere 35**

Martin Fischer & Peter Röben (Eds.)

Cases of Organisational Learning in European Chemical Companies.

Bremen, ITB 2002

ITB Arbeitspapiere Nr. 35

ISSN1615-3138

# Content

<b>1</b>	<b>INTRODUCTION .....</b>	<b>4</b>
<b>2</b>	<b>CASES OF ORGANISATIONAL LEARNING IN THE COMPANY B (BELGIUM) .....</b>	<b>7</b>
2.1	THEORETICAL LAYOUT .....	8
2.2	BACKGROUND OF THE STEAM CRACKER PLANT IN COMPANY B .....	10
2.3	DISCUSSION OF THE DIFFERENT CASES OF ORGANISATIONAL LEARNING .....	16
2.4	CASE 1: RE-EVALUATION OF STANDARD OPERATING PROCEDURES.....	17
2.5	CASE 2: COMPETENCE MANAGEMENT .....	25
2.6	CASE 3: THE SHAPING OF THE ORGANISATIONAL STRUCTURE OF THE STEAM CRACKER AS A FACILITATOR FOR ORGANISATIONAL LEARNING .....	42
2.7	CASE 4: HANDLING OF CRITICAL INCIDENTS .....	51
<b>3</b>	<b>CASES OF ORGANISATIONAL LEARNING IN COMPANY G (GERMANY) .....</b>	<b>59</b>
3.1	THE APPROACH OF COMPANY G TO ORGANISATIONAL LEARNING.....	59
3.2	CASE 1: THE USE OF WORK PROCESS KNOWLEDGE AND ITS INTEGRATION IN THE DOCUMENTS OF THE COMPANY AND IN THE QUALIFICATION SYSTEM.....	74
3.3	CASE 2: CHANGE OF THE CULTURE OF THE ORGANISATION SULPHITE FACTORY .....	89
3.4	CASE 3: ORIENTATION TO PROCESSES AS A REFERENCE POINT FOR THE INITIAL TRAINING IN COMPANY G. ....	96
3.5	CASE 4: THE MASTER AS A CATALYST IN ORGANISATION LEARNING.....	109
3.6	CASE 5: THE INSTRUCTOR (AUSBILDER) AS A INTERFACE BETWEEN ORGANISATION AND THE SYSTEM OF VOCATIONAL EDUCATION .....	118
<b>4</b>	<b>CASES OF ORGANISATIONAL LEARNING IN THE COMPANY I (ITALY).....</b>	<b>121</b>
4.1	SITE UNDER INVESTIGATION.....	121
4.2	CASE 1: SHARING AND RENEWING WORK PRACTICES THROUGH MOBILITY AND PROCESS INTEGRATION .....	128
4.3	CASE 2: DEFINING AND UPDATING PROCEDURES AND MANUALS FROM THE BOTTOM-UP .....	140
4.4	CASE 3: PARTICIPATION AND JOINT DECISION: A STRUCTURED MEETING SYSTEM.....	142
4.5	CONCLUSIONS .....	144
<b>5</b>	<b>CASES OF ORGANISATIONAL LEARNING IN COMPANY U (UNITED KINGDOM).....</b>	<b>151</b>
5.1	COMPANY U'S APPROACH TO ORGANISATIONAL LEARNING .....	151
5.2	CASE 1: THE SYSTEMATIC APPROACH.....	153
5.3	CASE 2: PROCEDURAL AND COMPETENCE DEVELOPMENT METHODOLOGY (PCDM) .....	155
5.4	CASE 3: SITE EXCHANGES .....	158
5.5	CONCLUSIONS .....	160

*Martin Fischer*

## **1 Introduction**

It is a major objective of the project OrgLearn to identify ways of organisational learning in European companies and to discuss their implications for vocational education and training. This deliverable comprises first results of an empirical investigation into processes of organisational learning in the European chemical industry. Large chemical companies from Belgium, Germany, Italy and the UK were involved in this study. Researchers in the OrgLearn project have carried out more than 100 in-depth-interviews and have observed the learning culture within these companies during numerous visits.

Results of research are presented now in the form of case studies. Each chapter begins with a general introduction to the background of the companies involved, to their production and products, to their staff and their employment policy, and to their learning environment. All authors then describe cases of organisational learning that could have been revealed through empirical research. It is important to note that these cases do not merely depict the intentions of the company management but real-life phenomena which could be identified by involving different persons from different levels of hierarchy and thus different views on the same phenomenon. Phenomena were related to criteria of organisational learning which had been developed within the theoretical framework of OrgLearn (see first project publication: Fischer, M. & Röben, P. (eds.): *Ways of Organisational Learning in the Chemical Industry and their Impact on Vocational Education and Training – A Literature Review*). This happened within the national research crews and also within an overall project meeting where the applicability of the OrgLearn criteria to the cases presented were intensely discussed. It is worth mentioning that cases presented in this publication meet some of these criteria to a considerable extent, but not all criteria could be applied to each case and sometimes only a few aspects of the case described could be related to a criterion. Thus, there is room for further assessment.

In the OrgLearn project such assessment and evaluation will be done in different ways. One method of assessment includes a quantitative survey through which project findings are intended to be validated. Another method is a strong participatory approach that is characteristic for the project's research methods. Next steps in the project will

comprise the organisation of in-company workshops involving staff from different functional and hierarchical levels in order to validate findings and to give answers to the question which categories of employees do (or do not yet ) benefit from processes of organisational learning. Further steps in the project include an international workshop where representatives from all companies involved will present their approaches towards organisational learning and experts will discuss implications for vocational education and training.



*Fernando Pauwels & Joris Van Ruysseveldt*

## **2 Cases of organisational learning in the company B (Belgium)**

### **A presentation of four cases of organisational learning in a steam cracker and an exploration of organisational learning**

In this paper we will first recapitulate our theoretical framework and provide a definition of organisational learning, which will be further expanded on, by making use of a number of criteria, which have been developed by the OrgLearn research consortium. After this short theoretical recapitulation, we will take a short virtual tour through Company B to end up at the steam cracker plant.

In a following part, our four cases of organisational learning in the steam cracker will be presented. This paper is structured in such a way that we will first give some background on a case, then discuss the case in detail and conclude by making the link with organisational learning.

A first case is about the *re-evaluation of standard procedures*. We will look at what a standard operating procedure is, what the role of a plant manual is and how operators can make suggestions for improvement on the standard operating procedures. A second case is the *competence management system* they have implemented at Company B and at the steam cracker. First we will look at the job of an operator, then investigate the organisation of labour at the steam cracker and indicate some pitfalls to finally show you how this is a case of organisational learning. In a third case we will look at the *organisational structure* of Company B and indicate how this structure provides learning and knowledge sharing possibilities, which would otherwise not be present. In a final case, we will describe a unique situation, which presented itself while we were doing our research, namely the occurrence of critical incidents. We will describe what happened and which initiatives were taken to prevent similar future situations.

In conclusion, we will present an overview matrix, showing how these cases are related to the five criteria of organisational learning.

## 2.1 Theoretical layout

Before we present the company and the resulting cases of organisational learning in detail, we will first recapitulate some important parts of our theoretical framework, as laid out in a previous publication (Fisher & Röben, 2001).

In his contribution to this framework, Mariani (2001) refers to an article by Snyder & Cummings (1998) who defines learning as organisational “to the extent that: (a) it is done to achieve organisation purposes; (b) it is shared or distributed among members of the organisation; (c) learning outcomes are embedded in the organisation’s system, structures and culture”. This definition of organisational learning emphasises organisational knowledge creation and dissemination. As a result, in this paper we will focus on the aspect of the construction, the distribution and the institutionalisation of knowledge. This implies that we will look at how new knowledge, that can be gathered from the environment or that can be created within the organisation, affects how organisational work routines are being evaluated. This structural aspect of learning and of knowledge creation, retention and dissemination forms one of the pillars of the framework as elaborated on by our research group. As Argyris and Schön argue, organisational learning in the sense of double-loop and deuterio learning “implies that the organisation has created a *structure* through which individual learning is permanently stimulated, documented and evaluated” (Boreham, Fisher et al., 2001: 132).

Berger and Luckmann (1966) give a description of the process of institutionalisation in their principal work ‘The social construction of reality’. How can this process of institutionalisation be regarded? Huysmans & van der Vlist (1998) define it as “a process in which social practices become sufficiently regular and continuous in order to regard them as institutions that have a normative, compulsory influence on the behaviour of members of an organisation”.<sup>1</sup> This process of institutionalisation can thus be regarded as a process, which is a central element to organisational learning to us, that individual knowledge is transformed into organisational knowledge.

Berger and Luckmann (1966) identify three stages that can be discerned during the process of institutionalisation: *externalising*, *objectifying* and *internalising*. The learning of an organisation can be looked upon from the viewpoint of these three stages.

---

<sup>1</sup> The author of this paper has made the translation.

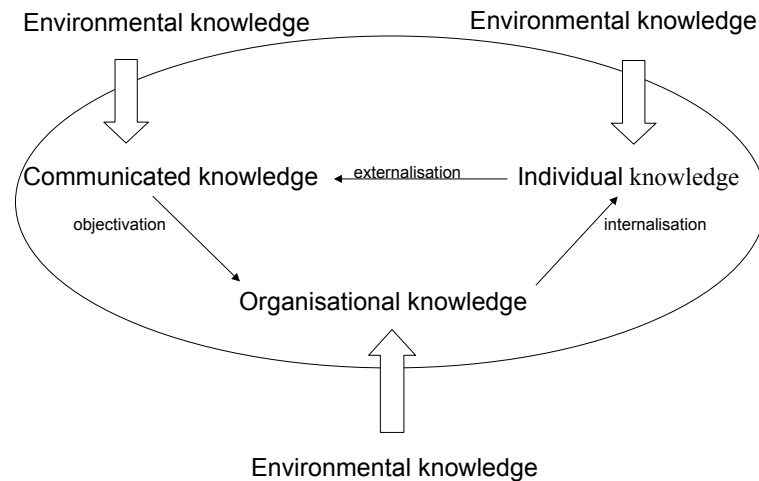

Source: Adaptation of figure, based on Huysmans & van der Vlist (1998)

**Figure 1 Learning as a process of institutionalisation**

During the process of *externalisation*, personal knowledge is transferred to others. This can happen in different ways, through formal and informal channels, by personal contact or by use of communication technology. This knowledge can be *objectified* by the organisation in the form of rules, procedures, structures, etc. and can thus function as a kind of organisational memory. This doesn't mean that this organisational memory is static. Objectified knowledge is also liable to change. Through *internalisation*, an employee reabsorbs this organisational knowledge, in order to become, and remain, a member of the organisation.

This process of organisational learning through the institutionalisation of knowledge, as described above, follows a circular motion. This however does not mean that this circle is fully closed. It is permeable to knowledge from the environment, which can influence the individual, the communicated and the organisational knowledge at any stage. This means that external knowledge can influence the individual, communicated and organisational knowledge at any time.

We can illustrate this process by means of an analogy of finding how to get from place X to Y. When an individual knows how to get there, we can call this individual knowledge. If he explains this to someone else, this is communicated knowledge. In order to avoid the repetition of explaining this to each person who does not know how to get from X to Y, he may alternately draw a map. This map is objectified knowledge or organisational knowledge. From the moment that other people start using this map, they are internalising this knowledge. What we try to study, is how these maps come into being.

Essential to this framework are the five criteria that have been developed by the Orglearn research consortium. These criteria that stem from the theoretical framework

will in a later stage be used to relate our cases. In a previous paper (Fisher & Röben, 2001), these criteria have been elaborated. In short, they cover the evaluation of the work routines and of the formal and informal learning processes, the transformations in the culture of the organisation, the creation and dissemination of knowledge and the learning from the environment.

In what follows, we will present several cases of organisational learning within the steam cracker plant of Company B, but first, we would like to present the company and the role of the steam cracker.

## **2.2 Background of the steam cracker plant in Company B**

We would first like to show you how the steam cracker plant is embedded within the Company B Group. In what follows, we will present several cases of organisational learning within this plant of Company B.

### **Company B**

#### **General introduction to the Company**

In 1865 Friedrich Engelhorn founded Company B in Germany to produce coal tar dyes and precursors. One hundred and thirty six years later the Company B Group has become one of the world's largest transnational chemical companies, with production plants in thirty nine countries and commercial representation in one hundred and seventy countries.

Company B in Antwerp was established on the 1st of December 1964. Construction began soon afterwards and production started in the middle of 1967. It is now the largest chemical complex in Belgium and the Group's major production unit after the Ludwigshafen site. The site itself is situated on the Scheldt estuary to the north of the port of Antwerp and consists out of 54 plants, which make up integrated production lines on a 600 ha site. With its direct access to the sea and to the European backcountry, Antwerp is Company B's premier maritime facility in Europe.

Apart from fertilisers and insulation panels, Company B mainly produces basic or semi-finished products, including basic chemicals and speciality chemical products used to finish paper and leather, for the production of detergents, paints, phytosanitary products, synthetic leather, etc.

## Employment

On average 4,572 jobs were filled at Company B in 1999. Of these jobs, 3,438 were filled by their own workforce and 1,119 by employees of contracting firms who provided a number of services to Company B. These subcontractors provide general technical services (construction, mechanical assembly and maintenance, electrical activities and process-control technology), logistics and dispatching, transport, catering, cleaning; which do not belong to the core business of Company B as a chemical company.

The effect on indirect employment is even greater. Based on their own calculations, using the total amount of orders placed by Company B (approximately 2.7 billion orders/year), close to another 9,000 jobs exist as a result of the activities of Company B in Antwerp (Company B Social Report, 1999).

As we have already mentioned, there were 3,438 people employed at Company B at the end of 1999. Of this workforce, 56% were workers with an employee statute.<sup>2</sup> White-collar workers make up 32% of the workforce and executives 12%. About 6% of the total workforce are women; among the white-collar workers, as among the executive staff, this is approximately 13%.

**Table 1 The workforce at Company B by statute and gender**

Per 31-12-1999	Men	Women	Total
Blue-collar workers (with employee statute)	1,936	1	1,937
White-collar workers	955	145	1,100
Executives	349	52	401
<b>Total</b>	<b>3,240</b>	<b>198</b>	<b>3,438</b>

Source: Company B Social Report, 1999

About half of the entire workforce of Company B works in shifts. About 70% of the blue-collar workers<sup>3</sup> work in a shift system. For white-collar workers, this number is about 39%. Although various shift systems are used at Company B, the most common system is a four shift system. In this shift system, each employee works one of the three shifts, eight hours in length, following a rotations system.

<sup>2</sup> This statute, which brings the classic blue-collar statute closer to the white-collar statute, was developed at Company B and implemented in 1995.

<sup>3</sup> These are employees with the aforementioned employee statute.

The way this shift system is organised explains why there are relatively few women with an employee statute. Up until April 8th of 1998, it was illegal for women to work during the night shift in the chemical sector.

**Table 2 The workforce at Company B by statute and shift**

per 31-12-1999	day shift	shift work
blue-collar workers (with employee statute)	573	1364
white-collar workers	670	430
executives	401	-
total	1644	1794

Source: company B Social Report, 1999

Also in 1999, the total personnel costs decreased by 1,1% compared to the year before, because of the lower number of employees and the fewer ‘incidental personnel costs’.<sup>4</sup>

Although situated close to the border of the Netherlands, with regard to nationality, the Belgians are with 90% still in the majority within the workforce of Company B. The Dutch and the Germans represent respectively 5% and 2% of the workforce, respectively. Employees from various other countries like France, the UK, Italy, Morocco, Austria, Spain, Rumania, Tunisia, Turkey and the US make up the final percentage. From this small percentile, 24 employees of the Company B group are in Antwerp to acquire international experience. Conversely, 24 employees of Company B have been sent to different companies of the Company B group for the same reason. Furthermore, there are 15 Company B ex-patriots who are temporarily working abroad on specific Company B group projects.

### **Age and Service**

When taking a closer look upon the age distribution of the company, we notice that about 40% of the workforce employed by Company B is within their thirties. The group in their forties form the second largest age group with 24% of the workforce, followed closely by those in their fifties at 21%.

<sup>4</sup> Incidental personnel costs entail contributions for fringe benefit provisions (retirement plans and precautionary funds) and costs originating from personnel transport, company catering facilities, work clothing, insurance, etc.

Figure 2 Age pyramid company B

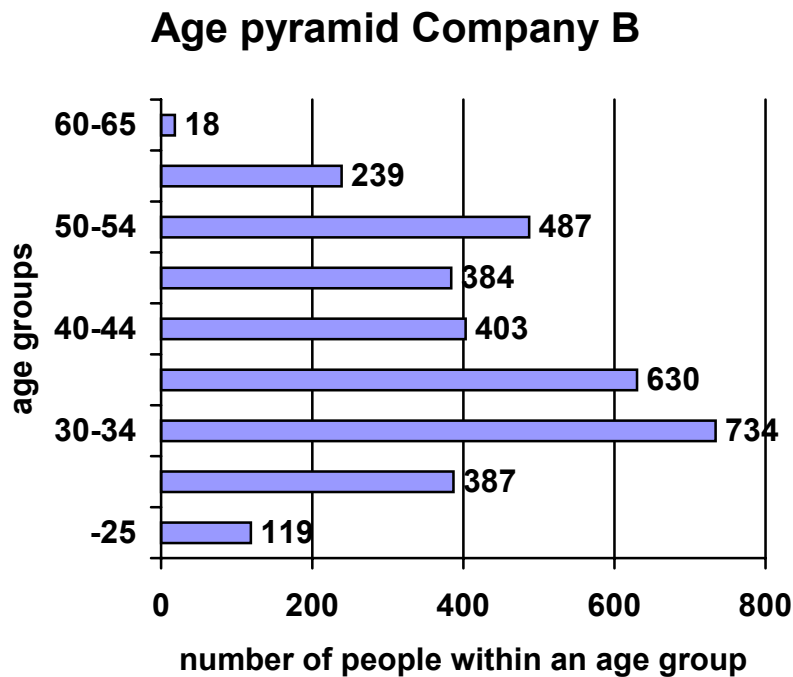

Source: company B Social Report, 1999

What is of particular interest, is that the number of persons in the age group of fifty to fifty-five is larger than the number of people in both the age group of people from forty to forty-four and forty-five to forty-nine. This means that when the people in the age group of fifty to fifty-four leave the company, Company B will lose experienced people it cannot replace immediately. And this is where the concept of a learning organisation, which tries to gather the knowledge and experience of its workers, can play an important role.

When we look at the seniority pyramid of Company B, what strikes us the most, is the fact that more than two thirds have a service record of more than ten years within the company, and that of this group, more than half have got a service record of more than twenty years.

### **Education and training**

Company B recruited 121 new employees during 1999. Of these newcomers, 75 were blue-collar workers and 46 white-collar workers and executives. During this year Company B received a total of 2,246 job applications of which 640 candidates were chosen to participate in the selection process. The yearly average of new recruits from 1995 till 1999 is 105.

Not only newcomers need training and education. To stay abreast of the fast developing technology, education and training plays a large role in the overall personnel policy. Thus Company B spent a total of 10,029 man-days and 101 million BEF on training and education in 1999, not including on-the-job training. This amount does not include the cost of the non-productive hours, which amount to an additional 115 million BEF. Training courses were followed by a total of 2,676 employees in 1999, which amounts to a cost of approximately 38,000 BEF per employee being educated and 3,8 man-days. What Company B tries to accomplish with all the training they give is “to afford employees the opportunity to acquire, maintain and develop skills with which they can carry out their duties and fulfil their role in the realisation of the company vision” (Company B Social report, 1999). It is also stressed that besides technical training there is also training oriented towards social skills and company values.

### **Verbund**

The word ‘Verbund’ is a derivative from the German verb ‘verbinden’ which means to connect, to associate or to integrate. This word is considered an established concept within the company of Company B Group and is normally not translated. The concept originates from the vision that Friedrich Engelhorn had when he set up Company B Group in 1865. What he wanted to do, was to bring dye research and production under the same roof.

His vision was to link each production facility to other plants so that the finished products and the leftover material from one plant could serve as raw materials for another plant. Today Company B is such a Verbund site,<sup>5</sup> where all the plants are connected with one another, by means of at least one product of one production process. In this framework, the construction of the steam cracker plant is a case of backward vertical integration, since it produces the base products for other plants. But the Verbund concept entails more than what is known as global integration (both horizontal and vertical), since Company B group also disposes of an energy Verbund, a logistics Verbund, an infrastructure Verbund, a market and customer orientation Verbund and last but not least a know-how Verbund. This last type of Verbund is related to the way knowledge is created and transferred within Company B. How individual knowledge is brought together, organised, evaluated and made available across departments, divisions and countries, will be shown in a following chapter, when we discuss several cases of organisational learning in detail.

---

<sup>5</sup> Besides the site in Antwerp, the Company B group has got a number of integrated plants in Ludwigshafen (Germany), Tarragona (Spain), Geismar (US), Freeport (US), Altamira (Mexico) and Guaratingueta (Brazil). Besides these, Company B is planning or constructing other integrated sites in Kuantan (Malaysia), Mangalore (India) and Nanjing (China).

## The Steam Cracker at Company B

We have just explained that Company B is an integrated site on different Verbundlevels. Although the steam cracker is one of the more recent plants at Company B,<sup>6</sup> it is partly the foundation of this Verbund structure, because it produces the basic products that are used in one way or another in most plants on the Company B site, namely ethylene and propylene.<sup>7</sup>

In the following section, we will give a short description of the production process. How does a steam cracker work and why is it called a steam cracker?

In essence, a chemical process always is a transformation process, where something is turned into something else. In the case of the steam cracker, naphtha is transformed mainly into ethylene and propylene. The naphtha that has to be 'cracked' is supplied by Tankpark, another plant at Company B. The naphtha Company B uses comes from all over the world, from Kuwait to Algeria and from Spain to Russia. A large part also comes from the refineries in the harbour of Antwerp. As we have mentioned before, the steam cracker plays a major role in the Verbund structure of the Company B site. Before they had their own steam cracker, Company B was a consumer for ethylene and propylene from Company Ludwigshafen. Now they are a supplier for these products, not only for their own internal market, but also for the external market.

Naphtha is then preheated in a feed preheater. In one of the ten ovens<sup>8</sup> the naphtha is evaporated and after dilution of the naphtha by adding steam, the molecules of the naphtha are cracked.<sup>9</sup> This happens at temperatures up to 850°C. This reaction product, called cracker gas, contains amongst other things hydrogen with some carbon monoxide, carbon dioxide and some sulphur carbon monoxide, methane, C2 (acetylene, ethylene, ethane), C3 (C3-acetylene, propylene, propane), C4, pyrolyse gasoline and pyrolyse fuel oil. The rest of the installation is then used to separate these different components.

After the reaction at a temperature of 850°C, which lasts for about one second, the cracker gas is then cooled down in different steps, in different columns, amongst others by use of oil and water. This oil then absorbs the warmth, the oil is then cooled off in a different system. In a fairly similar way water is used to cool down the mixture.

---

<sup>6</sup> The construction of the steam cracker started around March 1992, while production started at the end of 1993.

<sup>7</sup> The feedstock they use is mainly naphtha, although LP gas, propane gas, ...can also be cracked. This is what they call a combined cracker, with a gas-liquid feed.

<sup>8</sup> A new oven is being built at the moment to increase the capacity.

<sup>9</sup> Because the molecules of the naphtha are being decomposed or 'cracked' using steam, the installation is called a steam cracker.

Then to separate this product mixture, it is compressed so that it can be distilled or extracted into its different components. This happens in different stages, in a number of columns. We will not look at this lengthy process in too much detail, but what you end up with is mainly ethylene and propylene, which is produced in quantities of 730,000 ton and 430,000 ton per year respectively. To summarise we can say that by extreme heating or by extreme cooling down, the different molecules of the naphtha are separated and recombined into different combinations.

The transformation process that is going on in the steam cracker is a full-continuous process. This means that production is only halted, when something fundamentally goes wrong, or when there is a planned shut down.<sup>10</sup>

This process can be divided in three different parts, namely a hot, a cold and an auxiliary part. We will explain this in further detail in our description of the case of competence management. (chapter 4.2)

Maintenance and repair run parallel with production.<sup>11</sup> For instance every sixty days, an oven needs to be decarbonized. To get the naphtha up till a temperature of 850°C, methane is used to fuel the ovens. During this reaction process, the residue forms a deposit inside the tubes. As this residue is a perfect isolator, higher temperatures are needed in the tubes. This means that more energy must be used to reach the same temperatures. From a certain level, these cokes will need to be removed from the oven. This oven cannot be used for about 48 hours. But this does not mean that the production process is halted. Since there are ten ovens, one oven can always be cleaned. Although this means a reduction in the production capacity, the production process can still continue, while the others remain operative.

### **2.3 Discussion of the different cases of organisational learning**

In this section, we will discuss four different cases of organisational learning within Company B. In a first case, we will tell you about the ways in which standard operating procedures are being evaluated and improved by the workers. Here we will try to indicate in what ways these evaluations play a role in organisational learning. In our second case, we take a closer look at the competence management system implemented at Company B. Here, we will show how the complexity of the production process has led to the implementation of a competence management system and how this system

---

<sup>10</sup> These planned shut downs occur every five year and last about four weeks. The main reason they shut the production down is because of legal safety reglementations that have to be followed. This also allows for maintenance, for the removal of organic residue in the tubes and for the implementation of projects that cannot be run when the steam cracker is fully operative.

<sup>11</sup> This parrallellisation allows to combine production with maintenance and repair for some, not all parts of the production process.

can be regarded as an exponent of organisational learning. For our third case, we focus on the organisational structure, where we show that the way work is organised in Company B, provides a structural prerequisite for organisational learning. In our final case, we look at how a recent crisis was handled at the steam cracker and which lessons the organisation drew from this crisis.

## **2.4 Case 1: Re-evaluation of standard operating procedures**

In the discussion of this case, we will have a closer look at what a standard operating procedure is and what its significance is within the chemical industry. Furthermore, we will discuss the plant manual at the steam cracker as one of the ways in which these standard operating procedures can be conceptualised. We will also examine the ways in which workers themselves can make suggestions for improvement.

### **Standard operating procedure**

We can draw an analogy between the preparation of food in the kitchen and the production of a chemical substance (Huys R. et al., 2001: 32-33). In preparing a meal, you need all the necessary ingredients. But with these ingredients, it is possible to make a fair amount of different meals. To end up with the dinner you planned to make, you could either mix all the ingredients together and hope for the best, or you could follow a recipe. A recipe is an algorithm, a plan that tells you how the food should be prepared. During the preparation of food, by lifting up the lid of the pan, the cook checks whether every thing is going according to plan. These are interim measurements. The cook also intervenes, by adjusting the temperature of the stove. These same steps of setting up a plan, monitoring the process by regular measurements and intervening in the process are also a part of the production of chemical substances. There are of course still big differences between cooking and the production of chemicals, but it shows what a chemical production process is in essence, namely a transformation process of raw materials.

And just like in a recipe, there are procedures in the chemical industry that tell you what to do at a certain stage of the production in order to perform a certain operation in the plant. These standard operating procedures, like a recipe, are algorithms, which tell you what to do in which order. In our analogy, the standard operating procedures are not the recipe. Since the steam cracker is a highly automated plant, we can find the recipe in the physical layout of the plant. The standard operating procedures as we understand them are procedures for performing certain tasks to keep the plant operational. Since these tasks are crucial and safety and environmental risks are involved, procedures have been developed to carry out these tasks.

## Plant manual

At the steam cracker, these procedures have been written down in a plant manual. In former times, this manual was kept only in written form on paper. Now, this manual is maintained electronically and therefore, can be consulted by every worker from a computer terminal.

Originally, the plant manual was drawn up by the engineers of the firm that designed the steam cracker for Company B. But the steam cracker is a dynamic environment. New things are still added to the steam cracker, like for example a new oven is being built at the moment. Such technical changes, which are *planned*, are documented parallel in the handbook with their development, in order to keep the manual up to date.

Next to planned changes, there are also *unplanned* changes in the plant manual. These can occur on a technical level, usually when something unexpectedly has been changed in the installation. Such unplanned changes in the plant manual almost always happen when something goes wrong. When the plant is running smoothly, it is not always noted that some things could be handled more efficiently.

“Of course when everything is running normally, you don’t notice the problems. You keep your hands of the process and you ... optimise a bit to get more from the process, that yes, but apart from that, nothing happens.” (Interview KDV, 03/04/01: 10)

It is when difficulties arise, that people start to think how it could be better arranged in the future.

“Most of the times, when proposals are submitted, it happens when we have experienced some problems. (...) That is when you see the problems, otherwise you just overlook them.” (Interview JK, 03/04/01: 6)

The plant manual is thus updated regularly. As one of our interviewees put it:

“It is a sort of living book.” (Interview AN, 05/04/01: 9)

Although they keep a printed version of this plant manual, in a strict sense, it is no longer a real book, since it is the electronic variant that is used most widely.<sup>12</sup> At the steam cracker, there is a procedure for updating this handbook, which is fairly similar to making a suggestion for improvement, as we will see in a following section. A worker puts his idea of what could be improved in the handbook down on paper and hands it to his team leader. He reviews this and hands it over to management who also has a look at it and they put it into the handbook.

---

<sup>12</sup> The printed version is only updated a couple of times a year, the electronic variant is updated continuously.

Not only does this plant manual include the procedures in terms of knowledge, it also includes the transcribed experiences of certain workers with certain disturbances. These notations are put in incident reports.

“When certain people experience a disturbance, they put it in writing afterwards in order to remember it, when a similar incident happens. There are people who do this very individually, who keep that disturbance for themselves. This is a kind of job protection. We try to encourage people to share this information and to draw up an incident report, that then becomes part of the plant manual.” (Interview EDB, 29/03/01: 8)

In this way, the plant manual not only tries to transcribe the knowledge of an operator but also to capture his experience. But in order to use this knowledge and experience which is stored in the plant manual for organisational purposes, and thus for organisational learning, the information which it contains must be easily accessible and retrievable. In other words, you can store as much information as you want, if you haven't got an efficient way of retrieving this information, this databank of information is quasi useless. So just centralising knowledge and described experiences, is not enough for it to be organisational learning. Just having an organisational memory is not enough for organisational learning. It must also be possible to retrieve this information and to redistribute it among the workers.

As we have stated, the information must be easily accessible and retrievable. The first is certainly the case. A great number of PC's are available for the workers on which they can access the electronical information system. But (physical) accessibility is not always the same as the retrievability of the information. Some workers find it hard to retrieve certain information in the electronical plant manual. When asked whether the electronical plant manual was easy to use, our respondent replied

“No. (...) But from the moment that some one has got a question (concerning where to find something in the plant manual), we (team management) teach him where to find that information. For someone who doesn't use the system regularly, it is fairly complex to retrieve certain information.” (Interview JK, 03/04/01: 9)

The management of the plant certainly acknowledges this problem. They indicate that improving the existing plant manual is one of their priorities. Several initiatives are being undertaken to make the retrieval of information a less complex matter. One of the problems with the plant manual is that the text included is continuous, and that up until now, new additions to certain sections in the plant manual were added without placing subtitles or something similar. This makes it hard after a certain time to retrieve certain information. This is going to change in the future. Instead of continuous text, subparagraphs and subtitles will be used which can be included in the table of contents.

So improvements to the plant manual are possible and are also being made. With an electronic plant manual, the management of the steam cracker possesses a strong instrument for organisational learning, if it is used right way.

### **Suggestions for improvement**

The workers themselves can also add new knowledge to the plant manual by making suggestions for improvement, which can be taken up in the manual. The procedures are thus not entirely fixed, they can be altered, also by the workers. But the workers cannot change these procedures themselves.

### **Individual suggestions**

To change a procedure, the workers have to follow a certain procedure. To this end the steam cracker has a 'suggestion committee' at their disposal. Ideas for improvement that are specific for the steam cracker go through this suggestion committee. When a worker notices something that can be improved with regards to safety, quality, production output, environmental issues, be it the procedures or some technical aspect, he can fill in an 'improvement form', where he explains what and why something should be changed. This improvement form is then transmitted via the team leader to the suggestion committee. This committee consists of a representative from the plant management, one of the foremen and someone from the technical departments and a representative for production. Here, these suggestions are then discussed. If these suggestions are approved (not necessarily executed), the person gets a financial reward. Such suggestions can be made by all workers, regardless of their status.

### **Group suggestions**

Of course, such a system of individual rewards for individual ideas is not always beneficial for the quality of an idea. A competitive atmosphere can arise where each person tries to guard his own ideas and does not share them with others in order to reap the rewards for his idea. For this reason, they stimulate ideas worked out by groups of people. Like one team leader told us:

“In principle you can enter an individual proposal and then you get an individual reward. But at a certain time, we were thinking: if I am working on an improvement proposal, which takes up a lot of time, it can be that other people are working for you at that moment. Because you are working on the improvement proposal. (...) It is our intention, and this is also supported by the suggestion committee, to look at the ideas more like a group. A person still often writes the improvement proposals, but this person goes to discuss it with the other people from his team. Sometimes someone of the shift management reads this idea, and then the idea is submitted as an idea by that team. This team also gets the reward.” (Interview EDB, 29/03/01: 13-14)

The philosophy behind the group ideas is that a group of people can offer different perspectives and suggestions on an idea than an individual can on his own. At the steam cracker, we notice an evolution more towards group proposals. Team management therefore encourages group proposals.

### **Idea managers**

Other initiatives at a central level are being undertaken to go from individual to group proposals. Central management of Company B is planning to instate what they call 'idea managers'. Next to the rest of their work, these idea managers would then try to stimulate and capture creative ideas from different people and try to elaborate on these in a group. In essence, it is the same as the example above, except that a person is designated who will fulfil an intermediate role for stimulating and bringing together different ideas.

As some one from personnel management of Company B said:

“Among our employees, there is a lot of creativity present in the form of new ideas and experiences. We intend to use these in a consequent and constructive way. By implementing an idea manager, we try to counter the competition between our employees concerning creative ideas. Company B also has got an idea box, but we want to get rid of this philosophy of individual rewards for individual ideas. We intend to grab creative ideas at a plant level and elaborating them, not as an individual, but as a group. It would not become a separate function, but more like a role that someone takes upon him.”

This is an example of how the organisation tries to bring all different creative ideas together by having someone gathering all these ideas. Thus an idea manager can be regarded as someone who tries to gather knowledge from different people for organisational purposes. In this way, the institution of such a role can be regarded as organisational learning.

### **Incident reports**

As stated before, most suggestions happen when something has gone wrong. At such times, it becomes clear what is malfunctioning and which procedures can still be improved. When an incident happens, the workers at the steam cracker are required to write an incident report, of what happened and why. This is then included in the plant manual. These incident reports thus function as a kind of organisational memory of everything that has gone wrong at the plant.

But besides functioning as an organisational memory, the incident reports often acts as a kind of catalyst for suggestions on improvement. The function of an operator is of the nature that at certain times, he is extremely busy and when not he has almost nothing to

do. An operator has the time to think situations through and reflect on them in order to come to an improvement proposal.

“For reasons of principle, we are obliged to write an incident report, when there is a disturbance. This means, when there is loss of production, when environmental issues are at stake, when someone has been hurt. In such extreme cases, an incident report is always written. These are electronically stored and can be looked upon from time to time.” (Interview EDB, 29/03/01: 8)

### **Grey booklet**

At the steam cracker, workers have the practice of writing certain things down in a kind of little *grey booklet*. Most workers have a different notebook for every section of the installation (hot, cold and auxiliary) and carry these around with them when they work in a specific part.

“We also have a booklet of our own, for outside and for inside. In these, we write everything that we get passed through from our colleagues. I have learnt this practice from a control room operator, who had such a book. I have taken his book for a while and copied it and added my own things. I have got such a booklet for each different part inside and outside. When I don’t know how to perform a ‘hot start’ for example, I look in my booklet and see that I have to follow six steps. An other example is how to decoke an oven, described in our own words. You also find this in the plant manual, but having this booklet makes it easier, since you have written it yourself.” (Interview FVDB, 03/04/01: 7)

Most of the information that is included in the grey books, can also be found in the handbook. But sometimes when something goes wrong, it is crucial to have instant access to certain information. And experienced workers especially know what information is important to include in these booklets. This information is then written down in a condensed form in such a booklet.

When a newcomer arrives, he is assigned a mentor, who shows him around and who also lends him his copy of this grey book, so that the newcomer can make a copy of this information in a booklet of his own. In this way experiences of workers, of what is important to know, are transferred.

This is an informal practice, which does not originate from the plant management. And although it is an informal practice, there is a kind a structure present to stimulate the transfer of knowledge in these booklets by means of a mentor system. This practise is common (and we assume specific) for all operators, working in the Antwerp harbour. Although it is a practice of individual learning, it contains aspects of organisational learning. Workers do not all have to gather the information included in such a booklet

for themselves. When a new worker starts, this information is swapped between the workers and the experiences in them are thus transferred. From this viewpoint, we could say that it indeed bears aspects of organisational learning, which are not steered by the organisation.

But certainly one element of organisational learning is missing, being that there is no institutionalisation of information. The information is not centrally objectified which means that the information does not flow back to the organisation as such.

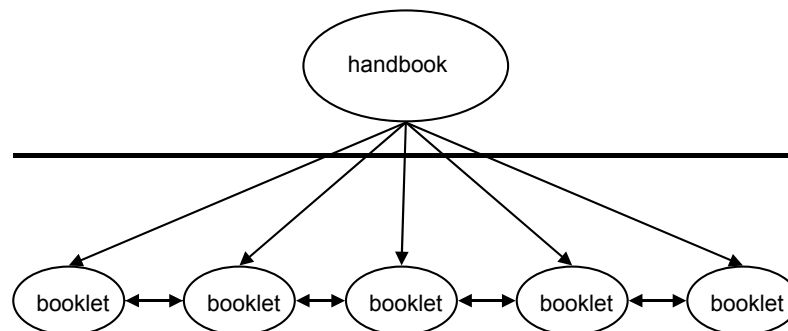

**Figure 3 Asymmetric information flow between handbook and booklets**

There is a direct information flow from the handbook to these little grey booklets. This information is then distributed among the workers by exchanging booklets. But on the other hand, there is no direct information flow from these booklets back to an important element of the organisational memory, namely the handbook. Thus because of this asymmetric information flow, we cannot call this interesting practice a case of organisational learning, although at first glance it does certainly bear several aspects of organisational learning.

In relation to this asymmetric information flow, we can ask ourselves who does benefit from organisational learning? Maybe the workers do this out of a worry to become obsolete. They want to have the feeling that they can keep some knowledge for their own. And because the management knows that what is written in these booklets is almost all included in the handbook, they allow this practice to continue, giving the workers the illusion of having a certain amount of control over their knowledge. But an operator at the steam cracker does not need to worry about losing his function. For the company, it is foremost his experience with disturbances that is of importance, and it is much harder to institutionalise this experience, than it is to capture his knowledge. Because of the highly complex layout of the process and of the importance of the experience of an operator, his function may be redefined in the future, but it will certainly not disappear anytime soon.

### **Link with organisational learning?**

Here, we will have a look at the way the different initiatives can be linked to the five criteria of organisational learning which have been drawn up by the research consortium. All these initiatives have to be seen in relationship to each other. Not scoring well on all five criteria does not mean that an initiative is not a case of organisational learning. Because of the interrelationship of all initiatives, they have to be regarded as elements of one case.

The use of an electronical *plant manual* adheres to criterion two and criterion five of our criteria, because a plant manual is an important tool for learning and for the transfer of knowledge within the plant.

The *suggestion system* and the *ideamanagers* comply with all five criteria, because as a result of these initiatives, work routines are being evaluated and altered, informal learning is stimulated; the three different cultures of the operators, the engineers and the executives are confronted and their different visions are presented and questioned; knowledge is created and shared and there is also learning from the environment. A newcomer, regarded here as someone from the environment can make very good suggestions on practices that people who have been working there for years take for granted. Numerous workers of the technical department gave us several examples of this. And the ideamanagers bring people and ideas together from different plants, which otherwise would have never met.<sup>13</sup>

The *incident report* meets three criteria. Work routines are being evaluated in these reports, learning is being stimulated by thinking of better ways of doing things<sup>14</sup> and since they are put into the electronical handbook, all this knowledge is shared within the entire plant. (criterion 1,2 and 4)

Although we cannot qualify the *booklets* as a means of organisational learning, because of the missing link of this initiative back to the organisation, certain criteria are certainly met by this initiative, and therefore we include it. Because each new worker is assigned a mentor who helps him during the first few months, there is a structure in place that stimulates informal learning. This mentor also lends the newcomer his booklet, so that the newcomer can learn from this and make a copy of his own. Thus a learning culture can grow, because all this knowledge is transferred between the workers. (criterion 4)

---

<sup>13</sup> Whether another plant of Company B belongs to the environment, depends on the viewpoint adhered. Since our unit of analysis is one specific plant, we can regard other plants/departments of company B as belonging to the environment of the steam cracker.

<sup>14</sup> These suggestions will hopefully end up in the handbook by means of the suggestions system.

## 2.5 Case 2: Competence management

In order to understand how the competence management system at Company B works, we first need to understand which functions are essential for the chemical industry in general and for the steam cracker more specifically. Three tasks have to be performed in order to keep the plant running, namely the task of an operator (inside and outside), the maintenance of the plant and the analysis of the quality of the product. Together with the tasks of management, these three tasks are essential for keeping the steam cracker, or any other chemical plant running.

The labour force in a plant like the steam cracker is rather limited. The steam cracker can be operated with a minimal occupancy of fourteen operators. With these people, the plant can be handled in case of a serious disturbance. Not included in these fourteen people are the maintenance personnel nor the quality analysis personnel, because technically speaking, they provide services to the steam cracker, and these services are provided by separate divisions within Company B.

However, in what follows we will also include these tasks into our presentation of the tasks at hand, because all these tasks are mutually interrelated.

### Operators

We can make a distinction between the job responsibilities of a control room operator and the responsibilities of a field operator. At the steam cracker, every worker is trained to be able to perform both.

### Control room operator

*Preparatory tasks* for a control room operator are fairly unexistant, since he takes over the previous shift. At the steam cracker, this shift transfer happens in two different steps. The team leader goes through the shift report that has been drawn up by the previous team leader on shift, and he briefs his workers. During a second phase, these workers then go and sit at the console where they will work that day (hot, cold, and auxiliary) and discuss what has happened during the previous shift with the responsible operator of the previous shift. Dependent on what happened, there can be documents the operator has to consult at the beginning of a shift. (e.g. incident reports, shift reports, updates on the plant manual,...) Although these tasks are essential, certainly for the transfer of information, the contribution of these tasks to his entire job responsibility is fairly limited and by its nature routine. But these preparatory tasks can influence the way and order in which the operator performs his *executing tasks*.

These latter tasks can differ very much dependent on the condition of the process. When the process is stable, or when the operator assumes the process is stable, these tasks

include controlling, regulating, optimising and starting and shutting down the steam cracker.

*Controlling* is essential, because neither the automatic alarm system, nor the measurement equipment can be trusted automatically. As these systems can fail, the operator functions as a kind of back-up for these failures. When the measurement equipment fails, this can mean two things. Either the instrument does not record deviation anymore and errors have then got to be reported by the field operator. This is why at the steam cracker, the field operators also take measurements when they go outside to check the installation in order to counter-check the measurement in the control room. Or an instrument can also give the wrong information. This is where the experience of a control room operator is crucial. If he takes the wrong decisions, based on this information, serious incidents could happen, as one of the workers mentioned.

“The optimiser didn’t work today. I hadn’t found a message why, but the targets he gave were impossible values of ten thousand. This is obviously not correct. I went to my boss and told him. He said: ‘Luckily, you didn’t start that’. Because then problems could really have been seriously big. You know, all these things do work, but you have to pay serious attention, otherwise things can get out of hand.” (Interview AN, 05/04/2001: 3)

Controlling can also involve anticipating on alarms, in order to prevent errors. When a parameter rises from day to day, an operator can extrapolate this and take preventive action.

“Sometimes, the filter of a pump needs to be scraped. And when the pressure of that filter is high, you can follow this up. That it is rising gently. This then needs to be scraped, to lower the pressure, and when this has not yet been done, you can see this, systematically.” (Interview, GVC, 05/04/01: 3)

The order, the time and the frequency of these routines depend of course on the stability of the process, but also on the way these routine checks have been taught to the worker. The way in which these routine checks have been taught can depend from person to person, but in general, there is a fair amount of uniformity in the way these checks are handled during a stable situation.

“There are more people who have done it this way. I have been taught to do it this way.” (Interview AN, 12/04/01: 2)

When the value of a parameter will go outside the specifications if left untouched, the operator has to *intervene*. If this doesn’t happen automatically, he has to be able to analyse the problem in order to assess the ways in which this problem can be solved. He then has to decide on the way the problem will be solved. There are some rules of thumb he can use, but most of the time, these rules of thumb are too rigid in order to

grasp the complexity and interconnectedness of the problems. That is where his experience as an operator comes into play. Most of the time, a problem can be solved in more than one way. From his understanding of the interconnectedness of the process, he can then take the best decision from this experience.

“Different temperatures are not all right, how does that come? If I do this to get the specifications all right, how does it come that this lowers then? It is a constant cat and mouse game.” (Interview AN, 05/04/2001: 3)

So having knowledge of the process and experience with the results of interventions go hand in hand in an operator task. The ‘procesverstaan’ (process understanding) is thus an important element of what a good operator has to know. Since the steam cracker already is a very complex plant, it is hard to acquire this understanding of the process, which takes up a lot of time. The interconnectedness of the process is also the reason why operators are trained to perform several jobs. In this way, process understanding is also acquired. Ideally, everyone learns the entire installation inside and outside, in order to be able to work in all section but also to have an understanding of what happens in one section if something else changes in a different section.

In the near future, this acquirement of the process understanding will even become more complex, since there are plans to install an ‘*optimiser*’ at the steam cracker. What is optimising, what does an optimiser do and which effects will this have on individual and organisational learning? Optimising goes beyond simply intervening in order to keep the process within the predetermined parameters. Optimising means changing the setpoints themselves in order to obtain an optimal production result.

In the highly automated working environment of the steam cracker, there are four controlling and steering levels. First, there is manual control. All the controlling and steering is done by hand. This is a typical situation during a start-up. A second layer is basic control. A third layer is advanced control. Advanced control is designed to counterbalance disturbances. Most of the steering happens automatically, except when the disturbance is of such a nature that certain parameters go beyond the boundaries of the model. At this point advanced control shuts itself down, and is reverted back to basic control. A fourth level, that has not yet been implemented on-line at the steam cracker, is the optimiser. This optimiser takes a lot more into account than advanced control in determining how the process should be optimised. Once the optimiser is implemented on-line, this optimisation process will then function automatically, without any steering from the operators. For the moment, this optimiser is only working off-line. This means that the optimiser calculated the optimal targets for certain pressures, purities, etc., and the operator still steers towards these optimal targets using advanced control.

One of the most important tasks of an operator is to respond effectively and efficiently in case of a *disturbance*. From this viewpoint, it is understandable that one of the notorious quotes of plant management is that ‘they are happy when their operators are not working, because this means that the process is running smoothly’. And for overcoming such a disturbance, having a good understanding of the entire process in its complexity is essential.

But by implementing this optimiser, it will only become more difficult for a newcomer to learn the intricacies of the plant. First of all because he no longer trains this ‘feeling’ for optimising on the board, as this function is automatically done by the optimiser. But also because the link between what you do at the board and what happens inside the plant will become less transparent. The ‘how’ and the ‘why’ of this automation no longer comes into view for the operator. And it is just this understanding of the ‘how’ and the ‘why’, of the complexity of the process that enables to successfully handle a disturbance. This thus results in the automation paradox.

The more automated a plant becomes, the less experience an operator can acquire in order to handle a disturbance. More automation, especially in an already complex working environment as the steam cracker, poses a potential threat to the entire plant. When the workers lose the feeling for the steering of the process, how will they be able to respond to a disturbance? We will elaborate this problem further in detail when we discuss the handling of critical incidents.

*Starting and stopping the process* is also one of the tasks a control room operator has to master. Planned shut-downs and subsequent start-ups occur every five years at the steam cracker. This is done to perform maintenance tasks that cannot be performed in a running company, and out of safety precautions.

“The main reason is that we are legally forced to do so. We have got devices that work on steam, that have to be inspected. Therefore European Standards have been devised.” (Interview NB, 28/02/01: 10)

Next to planned shut-downs, there are also unplanned (partial) shut-downs, like the one in March 2001. We will have a further look at this incident when we tackle the case of the handling of critical incidents. The operator regards a disturbance or a shut-down as an exciting time. When the process is running smoothly and stable, monotony can occur. But this is not the monotony of the (same) act, it is the monotony of the non act. As long as the process is running smoothly, it looks as if operators are hardly working. They look at a screen, drink some coffee and talk to their colleagues. As stated before, a plant manager is happy when his operators are not ‘working’, because this means that the process is running the way it is supposed to.

But this situation can change in an instant. At every single moment something can go wrong and for these moments, the operators have to be prepared.

“Sometimes you have too little to do, and five minutes later too much. Sometimes a lot happens at the same time, and then you are short of hands!”  
(Interview SB, 05/04/01: 8)

For an operator, this can create fairly stressful situations, they have little control over the timing of a disturbance and it can happen at every instant. Since they have to be prepared to intervene at all times, they are not free to do additional tasks.

### **Field operators**

A field operator at the steam cracker is responsible for a well-maintained outside of the physical installation. He works in the production installation itself and checks the outside of all the equipment. For this, he works in close contact with the control room operator in two different ways:

First of all, he can *inform the control room operator of defects* in the installation he discovered during one of the controlling tours. At the steam cracker, predetermined routes through the installation have been drawn up. In total eight different routes are possible, which cover the installation in its entirety. When a field operator does one of these routes, he takes with him a handheld computer, the size of a mobile phone. This computer asks for certain checkpoints for each route, which the field operator fills in. This helps to take him through the process and provides extra information about the process. This also forces the field operator to pass everywhere to make sure everything is all right. As one of the field operators mentioned:

“You have to fill in a certain number, but you are also supposed to check whether everything around is ok. When there is a temperature meter which indicates a hundred degrees, but besides it, there is a leaking pipe, you are also supposed to notice this.” (Interview, GVC: 2-3)

And automatic measurements inside the control room cannot replace the experience and the sensory perceptions of a field operator who walks through the installation. Although the inspection rounds are predetermined, the interpretation of a field operator of his perceptions, smells, sounds, his ‘feeling’ for the process remain crucial.

“When I show a new person around, I always say what and why I do something. Then you always let this person feel (a pipe) for himself or have a listen (at the sound a valve or a pipe is making). And this experience cannot be written down in a book, I think. That is different every time and subject to different ways of interpreting. You can’t say that a pipe is flown through, when... For instance, you open a valve very gently. If there is warmth on both sides of the valve, you could say that there is circulation, but that is not always the case. For instance when you expand a fluid to a gas, it cools off. It could

become colder, it could become warmer. That is something very specific that you cannot summarise like that.“ (Interview GVC: 8-9)

And even in predetermined, pre-set routinized tours, the field operators sometimes bring in their own creativity by passing by all measurement points of a route via a different way. As one of the operators told us:

“These tours, you can do them blindfolded. If you do them just for the meters, they are purely routine. You try to bring in some variation by taking another way, or by paying attention to something specific. Although the handheld computer prescribes a certain route, you write the measurements on a piece of paper and you fill them in later.“

When a field operator notices a disturbance, he informs the control room operator. What a disturbance is, can also be learned from experience, which is transferred from field operator to field operator.

“If things happen that are not normal, we report them immediately. For small things, like a pump that makes a lot of noise, ... if we don't find it alarming, we are not going to call up someone immediately. A water or a steam leak is not crucial. We report everything that has caught our eye and then action is being undertaken. (...) You learn from experience what is of importance and what not.“ (Interview GVC: 3-4)

Secondly, the *control room operator can also ask that the field operator checks* an anomaly in order to locate and identify errors. The control room operator can also give instructions to the field operator to make certain manual adjustments in the field like manually shutting down or starting engines or by-passing defunct machines. Because the control room operator has an overview of the entire process, he is the one who controls the process and if necessary, intervenes.

### **Organisation of labour at the steam cracker**

For the entirety of the workforce at Company B, competence profiles have been drawn up at the central level, as a kind of guideline for evaluation and development. The competencies for a worker are fairly broad defined. They entail the ability to co-operate, the commitment and the employability of a worker, his eye for Quality, Safety and Environment and for Integral Quality Care, his sense for innovation and change, his abilities for co-ordinating and guidance and finally his professional skill. These competencies are broadly defined, since they have to apply for the whole of Company B.

Each plant uses these guidelines to formulate plant specific competence profiles. At the steam cracker a system of job descriptions is used that fits within these competence profiles, ranging from Aa to G.

Table three shows us how it is used at the steam cracker. This table contains a lot of information about the way the work at the steam cracker is organised. Following the chart will be a detailed explanation of the chart itself.

**Table 3**

Maximum number	Job numbers			Minimal occupation
	1	2, 3	4, 5, 6, 7, 8, 9, 10, 11, 12, 13, 14	
1	G			
2	F	F		1
2		E	E	2
17			Bb-Cc	11
= 22				= 14

Source: Company B steam cracker, internal document

### White-collar workers

Since the nature of the production at the steam cracker is a continuous flow, a shift system has been devised. There are four different teams. The structure of each team of workers at the steam cracker is identical, so in what follows, a description of one of these teams will be presented.

At the steam cracker, each team has one team leader. Table 3 shows the number for this job is one. What are the competencies required for the job of team leader?

Firstly, he is responsible for the co-ordination of work in general. More specifically for the steam cracker, this means that he is responsible for the shift reports and the transfer between the shifts, for the quality of the raw materials and the products, for the well-being of his workers, for the environment and for the tidiness of the workplace. Secondly, he maintains an overview of the process and the work-in-progress. Thirdly, he also has to prepare the instructions. Furthermore, he carries the responsibility for his workforce. He takes care of the staffing, the follow-up training of his workers and he organises the evaluation discussions of his workers.

Table<sup>3</sup> shows that someone who is of a G- or F level can do the job of team leader.<sup>15</sup> The difference between these two functions lies in an extra responsibility for the G-level

<sup>15</sup> The letters used here refer to the competence profiles as they have been drawn up at the steam cracker.

person. He is responsible for the overall policy within the team. The G-level person is then the team leader, the F-level people can replace him, when he is not there. One of the two F-level persons is assigned to be the assistant team leader.

Between these two categories, F and G, there is a one-out-of-two rule. One of those people in these two categories has got to be there, to act as team leader.

For each team, there are two chief operators. These correspond to job numbers two and three in table 3. The installation of the steam cracker is divided into three different parts, a hot part, a cold part and an auxiliary part. One of the chief operators is responsible for the co-ordination of work, process control and optimisation in the warm and in the auxiliary part. The other chief operator then has a similar responsibility for the cold part of the installation.

During the interviews, it was being stressed that these two chief operators do not work independently but that they co-operate. This should not be looked upon as two different teams working side by side. It is the team leader who integrates jobs that are of importance to both chief operators, because everything that happens in one part of the installations can be of influence on another part of the installation. Because of this interdependence, people working in the different parts have to work as one team.

Someone who is F or E-level can do the job of chief operator. Someone from E-level must first of all, be able to apply plant specific quality-, well-being- and environmental instructions. Second of all, he must be able to conduct evaluation discussions with his workers. The difference between someone who is E- and F-level is that the F-level person must have the abilities to replace the team leader, and must be able to draw up a good qualitative and quantitative occupancy of the team.

Looking at the categories reviewed thus far, they range from E to G. The persons within these categories all have the statute of white-collar worker. In our table<sup>3</sup> above, we can see that there is only one G-level person, two F-level and two E-level persons. These five people make up the shift management. For the shift management, there is a three-out-of-five rule. This means that of these people, at least one team leader and two chief operators have to be present at the steam cracker at all times.<sup>16</sup>

This three-out-of-five rule is possible, because everyone at the plant is trained towards knowing the entire process. For example, when looking at the job description of a

---

<sup>16</sup> Several combinations of minimal occupation are possible:

- 1 G (team leader), 1 F (head operator), 1F (head operator);
- 1 G (team leader), 1F (head operator), 1 E (head operator);
- 1 G (team leader), 1E (head operator), 1 E (head operator);
- 1 F (assistant team leader), 1 F (head operator), 1 E (head operator);
- 1 F (assistant team leader), 1 E (head operator), 1 E (head operator).

person of an E- or F-level, you don't find an E-level person, trained for the hot part alone, or for the cold part alone. Someone of E-level must know it all.

### **Blue-collar workers**

If we take a look again at the table above, we see that there are still eleven job descriptions left about which we have not yet spoken. In a minimal occupancy situation, there must be at least five control room operators and six field operators.

A team leader, two head operators and eleven operators can run the entire steam cracker. If we look at the different sections of the steam cracker, we notice that for the hot part, there is one control room operator, for the cold part there are two. For the auxiliary part, there is only one control room operator. It is their responsibility to co-ordinate the steering of the process at the board in the control room and to have the necessary samples taken and analysed.

Furthermore there are two field operators for the hot part, two for the cold part and one for the auxiliary part. They co-ordinate the activities outside in their section of the installation in close consultation with the person responsible for the process steering inside the control room of the same section.

The operator functions are filled by people who are either Bb, B, C or Cc by category. Basically, the main difference between these categories lies in the knowledge of certain parts of the installation inside and outside.

People at the B-level are required "to have knowledge of a certain part of the installation outside. This also implies that they must be able to operate this part of the installation independently when they have been given instructions." (Internal note Company B) It is up to their own personal preference, in which of the three parts of the installation they start.

The Bb-category is the next category a worker can be promoted to. Here the person has to make a choice whether to learn another part outside, or to get to know the part they already know outside in the control room. This means that people in this category "must have knowledge of and be able to operate two parts of the installation outside (hot and cold, hot and auxiliary or cold and auxiliary) or they must have knowledge and be able to operate one part of the installation outside (hot, cold or auxiliary) and have knowledge and process steering capabilities of a part of the process steering system, so that they can work independently as the second man at this console." (Internal note Company B)

The following category is the C-category. Someone of C-level "must have knowledge of and be able to operate the entire plant outside (hot and cold and auxiliary) or must

have knowledge of and be able to operate two parts of the installation outside and be able to steer the process from the console in the control room (hot and cold, hot and auxiliary, cold and auxiliary). Furthermore, this person has to be able to draw up a shift report and complete a good shift transfer. Besides having global knowledge of all plant specific quality-, well-being-, and environmental instructions, this person must have detailed knowledge of the concerned quality-, well-being- and environmental instructions. This person must also be able to apply this knowledge. Finally, this person must also have detailed knowledge of all security systems and of all permits at the steam cracker.” (Internal note Company B)

The final category of workers is the Cc-category. Some one who reaches this level “must have knowledge of and be able to operate the entire installation inside and out at all three consoles (hot, cold and auxiliary).” (Internal note Company B)

The categories as they have been presented here are cumulative categories. As we have seen, the category of workers goes up to Cc. It is the policy of the steam cracker that everybody who starts here, can reach this level.

“Not everybody will become Cc, but everybody can become Cc if they have got the competencies as they are being described.“ (Interview NB, 15)

There is a great deal of flexibility built in the way a person can learn the plant. Workers have the freedom to choose which parts they want to learn outside and/or inside and in which order they want to learn them. This competence system is organised in such a modular way, that everyone can get to know the whole production process of the steam cracker following the distinction outside/inside and hot/cold/auxiliary.

And although there are some restrictions, like first learning a part outside and then inside, this flexibility gives the worker great control over the way he plans his career. Also, not everyone has got the ambition to become Cc. Some workers prefer only to work inside or outside, or only in a certain part. And although the training at the steam cracker is aimed at stimulating polyvalence, this is also possible

But there are also some boundaries to this flexibility. We have seen that for all the categories, certain competencies have been drawn up. And in order to get to a higher category, these competencies have to be acquired. But not only is there a link between the category and the competencies, there is also a direct link between the category acquired and the wage received. You get an increase in your wage, when you have acquired the competencies of a higher category, and when you are actually promoted to this category. And although newcomers can opt to start in any of the three sections, most of them start in the hot section, as one of our interviewees pointed out.

“Most of the time, people start with the ovens, (...) That is fairly complex and it takes a while to get to know it thoroughly enough to get a raise. In the hot part, you can do it in one year, and have enough knowledge about it to be eligible to get a raise. For the cold part, that takes at least two years, two years and a half.“ (Interview GVC: 8)

Since some competencies are more easily acquired than others, in this case the technical competence of getting to know the hot section, the flexibility the workers have when they start, is bounded by practice. This bounded flexibility is not necessarily a bad thing. Since newcomers start in an easier section, they will probably not be overwhelmed by the complexity of the entire process.

Another restriction on the freedom of choice, can be the acquired level of the other workers in your team. This is dependent on the policy the team leader has implemented in his team. It is possible that he asks first to learn a certain part, because he needs more people in his shift to occupy a certain position.

“A person who is new at the plant has to follow a number of courses. Afterwards we haven't got a procedure where this man has got to develop according to the following steps in the following year. It depends on whether this man first learns the hot or the cold part. But some teams require that first the hot part should be learned outside and inside.“ (Interview FW, 05/04/2001: 6)

In terms of the work, a distinction is made between a control room operator and a field operator. In the competence profile, however, this distinction is not explicitly made. There is no separate competence profile drawn up for a field operator or for a control room operator. Everyone is trained towards polyvalence, towards knowing everything outside and inside. In the end, everybody can become Cc.

There are two more categories that haven't been mentioned yet, namely the Aa- and the D-category.

The Aa-category is the category in which a newcomer starts at the steam cracker if he is without previous experience in a chemical plant. A list is available of things this worker has to know after two months, six months and twelve months. Someone who is of Aa-level is not counted as a member of the team occupancy. It is only from level B on that a worker is regarded as an employable.

The D-category is a kind of intermediate category for those who are Cc and in who the plant management sees the potential to become a member of the shift management. Not everybody gets the opportunity to become a member of the shift management. First of all, there has to be a vacancy to become E, F or G level. Second of all, you have to be chosen by the shift management.

There is also one job number left of which we have not spoken yet, namely job number fourteen. This person acts as an extra field worker who can be assigned to do work in all three parts.

It is now possible to convert some of the information available in table 3, into an organisation chart, that sums up what we have mentioned before.

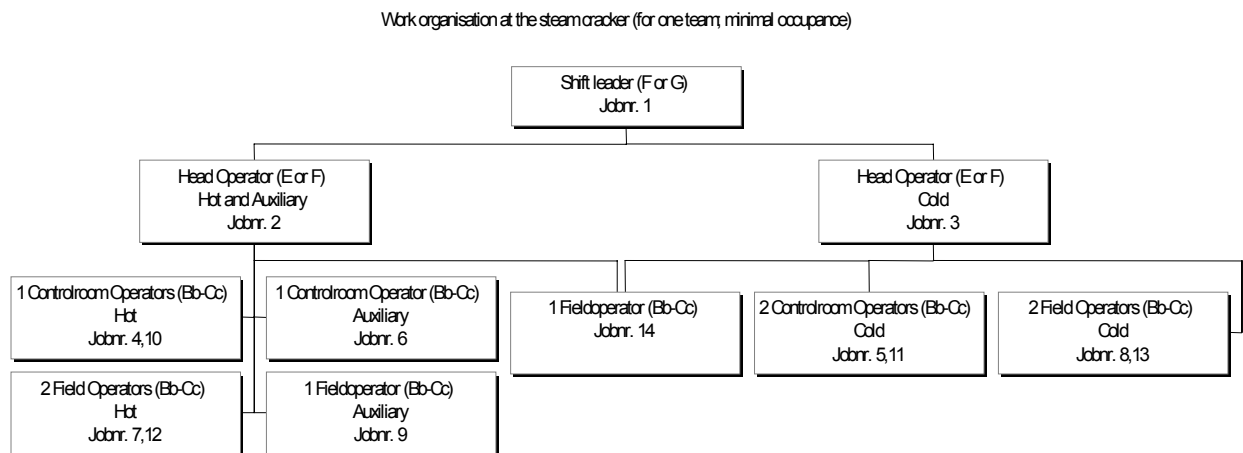

**Figure 4** Work organisation at the steam cracker

The situation as described here, is the minimal occupancy situation in one shift. It is possible that at one time, more than eleven people are working in one team. There is a maximum number of seventeen workers at the plant. Add to this the five members of the shift management. Thus, we become a total number of twenty-two team members.

This is in short the competence management system as it is used at Company B. Management keeps track of who has got what competencies by means of an electronic registration system. Since this is a highly transparent system, which everyone can access, only technical skills are kept track of.

### Pitfalls

The role of the team leader is of great importance for evaluating the competencies a worker has acquired. For promotions, a yearly planning is drawn up for every individual by the plant management. The plant manager then takes the decision about a promotion in close consultation with the team leader. Although the end responsibility for a promotion is attributed to the plant manager, the vision of the team leader is predominant, since he knows his team members better from every day work and can assess their qualities better.

For education and training, the team leader has the sole responsibility. This is handled, by the team leaders own discretion, independent of the management. As the plant manager told us:

“He knows best what everyone can do and what still is needed in terms of training, I leave this totally up to him.” (Interview FW, 05/04/01: 4)

Training and promotion cannot be looked upon independently. Acquiring competencies is a prerequisite for promotion and competencies can only be acquired by some form of training. Although training and education is the sole responsibility of the team leader, plant management is indirectly also in control of the training in the teams by drawing up a yearly promotion planning for each individual worker.

But this control is still an indirect kind of control. Each of the four team leaders can still shape the way he sees training and education within his team independently of the other team leaders or of management. As a result, there are fairly large differences in the ways the different team leaders handle their team specific training. Typically, a distinction can be made between two different approaches, what we call the ‘knowledge-oriented’ approach and the ‘experience-oriented’ approach.

Imagine two newcomers who start at the steam cracker. One starts in a ‘knowledge-oriented team’ and the other one starts in a ‘experience-oriented team’. The first type of team is very oriented on following the procedure to the letter and on the acquisition of knowledge. The management of this team require that this person goes through the plant manual first, that he can answer certain questions about a certain part of the plant, that he has coloured in the outline schemes of the steam cracker, that he has studied the process schemes and that he can draw the pipes and the pumps, ... This type of team will first go through the entire procedure and will try to transfer the knowledge in a very strict, predetermined way. The other person, who starts in the more ‘experience-oriented’ team, will be taken outside by one of the experienced workers and they will for instance start a pump. Not much paper work will be drawn up and the training will be more informal. While the other type of team is oriented more toward the book knowledge, this type of team prefers on-the job training and learning through the transfer of experience. They will go round the plant to see what goes through that pump and where it comes from. And although this type of team also follows the procedures, their orientation towards them is not that formalistic.

So in essence there are two types of handling training at the steam cracker. There also seems to be a close connection between the type of team and the performance in handling disturbances. Overall, these two types of team perform equal, but the type of

team that put the transfer of experience up front is performance wise slightly better in handling a disturbance than the type of team that is oriented towards book knowledge.

That the teams differ from each other where education is concerned can for a part be better understood if we bring in a historical perspective.

“It is still a heritage we have of ten, twenty years ago, when Company B was a collection of independent companies where every company was a kingdom of his own.”  
(Interview FW, 05/04/01: 7)

In the plants of those days, the plant manager and the team leaders held absolute sway over the plant and over the teams. These different team leaders all went their own way, without much interference from outside. So without much outside control, large differences arose between different teams.

At the site level, Company B is now trying to create more uniformity, but the team leaders present today, are all people who started ten to twenty years ago and they still have got the bias from earlier days that they can run their own team according to their own vision. This vision has through the years often become a part of the subculture of a team in which each newcomer is socialised.

Numerous definitions can be given of what culture is, but in our research, we have opted for the definition of Schein. He defines culture as “a pattern of shared basic assumptions that the group learned as it solved its problems of external adaptation and internal integration, that has worked well enough to be taught to new members as the correct way to perceive, think and feel in relation to these problems.” (Nonaka & Takeuchi, 1997: 58)

The culture of an organisation can be looked at from different levels, the culture of an organisation as a whole, the culture of a plant, the culture of a group of people, etc. When we look at the culture of a team, we have opted to call this a subculture, since this subculture still has part in the overall culture of the organisation.

Such a subculture of a team can become part of the identity of a team, which the team is not willing to change, since for example changing how the education is handled would be a fundamental change in the identity of a team and could lead to an identity crisis of a team. According to this viewpoint, the way education is handled in a team, can be regarded as a shared basic assumption that is perceived as the only correct way within this team. In this way, the teams could see trying to get more uniformity between the different teams by implementing changes from outside, as an infringement on their identity.

How does the plant management try to get more uniformity between the different teams concerning the way education is handled? A few initiatives have been undertaken by the plant management to try to get more uniformity in the way training is handled.

Each year, the plant manager has four meetings with all his team leaders, in which he addresses certain actual topics. One of the topics that was discussed at the most recent meeting was the difference in training in the teams. The plant manager brings his team leaders together in order to come to an understanding between the different team leaders. Another way in which the plant management tries to bring the four teams closer together in terms of education, is by the implementation of a uniform, easy to use, way of registering which training has been followed by which person.

Another initiative to bring the more than fifty different plants closer together was taken at site level by the implementation of the Quality-Wellbeing and Environment-system. These are guidelines regarding quality, well-being and environment that must be followed by every plant. But this initiative is oriented more towards getting the different plants, not just the different teams, in line with a mutually shared Company B culture. (Note that this Quality-Wellbeing-Environmental-philosophy is implemented top down, whereas the culture of a team has grown bottom-up.)

How then could the plant management work within the steam cracker towards getting more uniformity between the different teams? By being aware that cultural change cannot be successfully implemented top down. Since external changes that touch the essence of the culture of a group will not be accepted if they are not supported by this group. So getting the four different team leaders together to discuss their different viewpoints on training and education is certainly a first step in creating a mutual understanding. A suggestion we would like to make, in order to tackle the problem of the diversities in the in-team training, would be to rotate workers between different teams. Several scenarios are possible.

Newcomers of Aa-level, who are not yet counted in shift occupancy, could be rotated between the different teams, before they are assigned to a team. This way, the newcomers who have not yet been immersed in the subculture of one specific team, will become acquainted with the different types of training, of handling problems, of working, ..., with the different cultures of the teams. Since these workers are not yet counted in the shift occupancy, the problems that could occur by rotating them throughout the different shifts could be limited to a minimum.

This would however have the disadvantage that after this initial period, they would work within the same team, in which culture they would be socialised. So in the long run, uniformity would not yet be realised.

Another scenario that takes this objection into account would be to rotate the workers to another team when they (are about to) receive a promotion towards a higher category. In this way, it would be possible to rotate between different teams and to become accustomed to different ways of working and learning. If you could use such a system together with a well developed individual competence database, which would list the individual competencies of each worker, the teams would become more uniform, knowledge and experience transfer would be augmented and organisational learning would be stimulated.

Since it is within the competence profile of the team leader to take care of staffing and to follow up the education of his workers, he has got a big responsibility for the course of the career of his workers. First of all, he is responsible for the day to day staffing. This means that he has to assign certain people to certain jobs. Within a team, there are rotational rules between jobs, but these differ for each team. The plant management has not enforced one general rule. It is the responsibility of the team leader to organise his own team. Secondly, he is also responsible for the occupation of the team in the long run. For this reason he is also responsible for the education of his staff. He has got to make sure that at all times, there are enough competent staff to fill in all the jobs. This can of course mean a restriction on the freedom of a worker to choose which part of the installation he wants to learn next.

“If you look at our registration system for the training, you see that acknowledging that a worker has got a certain competence, happens by the team leader. It is a co-ordinated something between the top five, but as a team leader, he is responsible. (...)“ (Interview NB, 28/02/01: 16)

In this way, the team leader, in consultation with the rest of the top five of a team, is of great influence on the course of a workers career. Note that the role of the plant management herein is rather limited. As we were told by the plant management:

“These are things that are organised on a team level and in which we give the team a great freedom. If there is a shortage of good operators, we will notice this too. We do follow this up, but not on a daily basis. It is his (the team leaders) job to do that.“ (Interview NB, 28/02/01: 16)

Because of his responsibility for a decent long term occupation of his team, he is also responsible for the education and training in his team.

### **Link to organisational learning**

In this case description, we have investigated the function of an operator and at the organisation of labour at the steam cracker. Consequently, we have taken a closer look at the competence management system that has been set up at the steam cracker.

Finally, we have addressed some pitfalls. But how is this competence management system related to organisational learning?

We have already brought up the fact that the steam cracker is a highly complex working environment, where it is difficult for an individual to have a complete overview of the entire installation. Furthermore, not all operators need to know the entire plant.<sup>17</sup> So the knowledge of the entire process is divided among the different task performers.

“Our viewpoint is that everyone in a team knows something, and that I alone don’t know everything.” (Interview JK, 03/04/2001: 13)

By means of this competence management system, the management of the steam cracker can monitor whether there is enough knowledge and experience with all the different parts of the steam cracker within each team. This competence management system is thus a learning tool for (the management of) the organisation to keep track of a balanced distribution of experienced and less experienced operators in different teams. In this sense, the ‘organisation’ learns, because if necessary, if the distribution in a team is not balanced, management could possibly intervene in the work routines of a team and try to transform the culture of a team as we have addressed in the section about the pitfalls. But maybe this should better be called organisation learning instead of organisational learning.

Furthermore, although no one is forced to become fully polyvalent, thus to become of Cc-level, the operators are stimulated to get to know the entire installation. Further learning, by getting to know more parts of the installation is encouraged by the coupling of this competence management system with the wage system as described.

Because people with different competencies are mixed in one team, and everyone is encouraged to know the entire process inside and outside, people can learn a lot from each other. This case of competence management matches our first criteria, where work routines in general are monitored. With regard to the second criterion, which is about formal and informal learning, our case also scores well, because of the implicit assumption that everyone can become of Cc-level, and thus polyvalent. Thus learning is stimulated in this way. Furthermore, informal learning is stimulated because of the combination of a mentor system in one team, of a mix of people at different competence levels in one team and of the structure of an operator job, which allows free time to be used for learning. A similar argumentation can be provided for the fourth criterion, which is about knowledge creation and sharing. This case, as mentioned in the section about the pitfalls, demonstrates the possibilities of using the competence management

---

<sup>17</sup> Every one can become of Cc-level, but this is not a requirement.

system to align and transform the culture of the different teams, which complies with the third criterion.

## 2.6 Case 3: The shaping of the organisational structure of the steam cracker as a facilitator for organisational learning

In this case, what we will try to show you is how the way that Company B is organised, affects the organisational learning process. As stated before, organisational learning as it has been defined “implies that the organisation has created a *structure* through which individual learning is permanently stimulated, documented and evaluated.” (Boreham, 2001: 132)

We will show you that the learning that occurs as a cause of this organisational structure is organisational learning, namely that first of all, it is done to achieve organisation purposes, secondly, that it is shared or distributed among members of the organisation and thirdly, that the learning outcomes are embedded in the organisation’s system, structures and culture. (Snyder and Cummings, 1998 as cited in Mariani, M., 2001: 67)

But first, we will have a global look at the way Company B is organised. We will indicate how the steam cracker fits within this picture and how the way in which the organisational structure is filled in, facilitates organisational learning.

### Structure of Company B

Understanding the way in which Company B is organised is of great importance for understanding the organisational structure of the steam cracker plant. This is why we present a global overview of Company B.

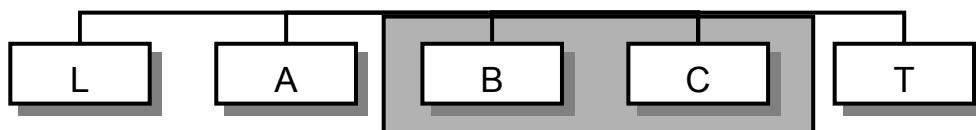

Figure 5 Structure of Company B in five departments

The company of Company B can be divided into four different units. A first unit consists out of the management of Company B as a whole (L). Administration (A) can be considered as a second unit and the technical department (T) as a third unit. Everything that has got anything to do with technical aspects, is handled here. A fourth and final unit of the organisation is made up by production. For the moment, the difference is still made between the two production units B and C. In the near future, this is going to change. We were told by the personnel department that Production I (B)

and Production II (C), which are now still separated, will then be united into Production (P).

But at the time of our research, this was not yet the case. Company B still consisted out of five different divisions. At the head of each division, we find a director. The different heads of these parts make up the Board of Directors, where as the director of the management of Company B (L) is the Chairman of the Board of Directors.

Within each of these five different divisions, there exist different departments. These different departments are responsible for a core activity of the company and they group services (A, L, T) or production plants (B, C). A head of the department is in charge of each of these different departments.

### The steam cracker plant within Company B

Within the division of Production 1 (B), we can make a distinction between four different production departments, namely BA (anorganic basechemicals), BB (organic base chemicals), BM (fertilisers) and BV (vinyl – and acrylproducts).

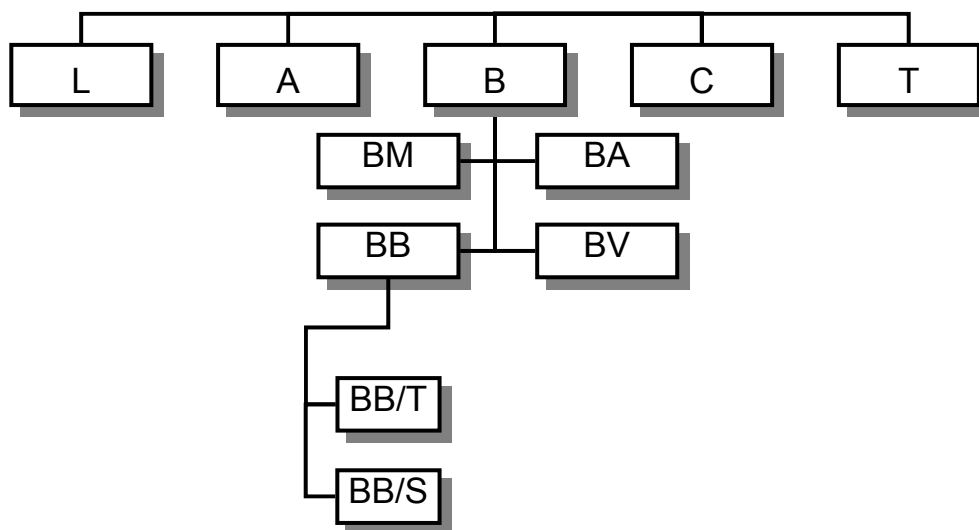

**Figure 6 Company B, including the departments and plants of B.**

Each of the other divisions of Company B is also divided into several departments, each with their own heads of department. Within each department of part B and C, we find several production companies, but to list them all here, would take us too long.

The steam cracker (BB/S) is one of the two companies we find in the organic base chemicals-department. The other company is Tankpark (BB/T). Technically speaking, this is the steam cracker as we have referred to it in a previous part, when we discussed the competence management system. In these competence descriptions, no technical

maintenance or automations tasks are mentioned. Operators provide little to no technical support for their own plant. Still, a steam cracker cannot function without this support. An operating steam cracker involves not only people from BB/S, but also from the technical division.

Within the technical division, we can make a distinction between two different departments, namely the mechanical maintenance department (TM) and the department responsible for the automation/instrumentation (TA).

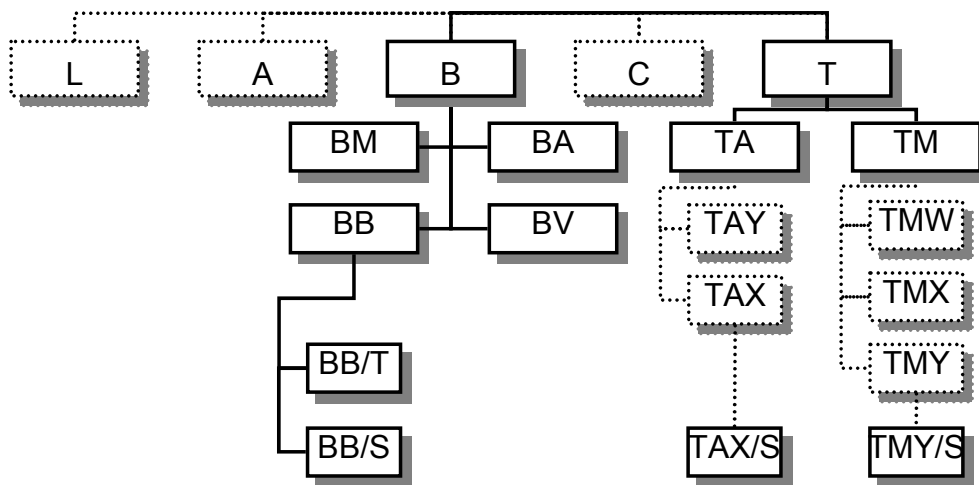

Figure 7 Company B, departments B and T.

Within these two department, several other distinctions can be made, which are not of great importance for our research.<sup>18</sup> What is of importance for our research is that there is one team of people of mechanical maintenance (TMY/S) and one of automation/instrumentation (TAX/S) that provide services solely to the steam cracker.

And because the steam cracker is such a large and important plant, the people from these teams work dedicated to the steam cracker. This means that they do not do the technical support for any of the other plants, that they only work for the steam cracker.

The work organisation in TM and in TA is fairly similar to the work organisation at the steam cracker. At the management level of the steam cracker, which up till now we have not yet discussed, there is first of all the plant manager. His background is that of

<sup>18</sup> The X and the Y in TMX, TMY, TAX, TAY used to refer to a geographical division, where companies on the north side of the site would be served by TMX and TAX and companies on the south by the others. But since the size of the Company B site has increased throughout the years and new plants have arisen, this geographical dispersion could no longer be maintained and now both the former geographical divisions provide services throughout the entire site. TMW refers to a central workplace of mechanical maintenance, which TA also uses for central maintenance. Not all the mechanical maintenance work has got to be done at plant level. For instance, pumps whose technology is not specific to just one plant, can be repaired at a central level in this central workplace.

an engineer. He has got the end responsibility for everything that goes on at the steam cracker.

This plant manager has got six assistant plant managers beneath him, of which three are responsible for one section in the installation (hot, cold or auxiliary). The three others then are responsible for projects and optimisation of the plant.

Furthermore, you have four foremen, of which three are responsible for each section of the plant (hot, cold and auxiliary) and a fourth one who handles more general problems. These people all work during the day shift.

At the teams of TA and TM that work dedicated to the steam cracker, a similar work organisation exists. At the head of TAXS, there is one plant engineer, who is at the same hierarchical level as a plant manager. Beneath him, he has got two assistant plant engineers, one foreman and two corporals. This function of corporal we do not find at the steam cracker. Although these people are formally lower in ranking, they can apparently do the work of a foreman and replace him if necessary. And finally you have the workers, who do most of the work in the field. And at TMYS you have a similar structure, with a plant engineer, three assistant plant engineers, one foreman and two corporals who can replace this foreman. And then we find the workers at TMYS, who do most of the mechanical maintenance in the field. Basically, the organisation of the management looks fairly the same in our three teams:

**Table 4 Organisation of management at BBS, TAXS and TMYS.**

	BBS	TAXS	TMYS
Plant engineer/manager	1	1	1
Assistant engineer/manager	6	2	3
Foremen	4	1 (+2)	1 (+2)

Note that we have included the corporals with the foremen. Although they are of a lower category as the foremen, they were often referred to in our interviews as being and acting as foremen. So that is why we have included them here.

These three teams keep the steam cracker operating. So we can observe that the steam cracker in operation depends on the close co-operation between the two parallel working divisions, B and T.

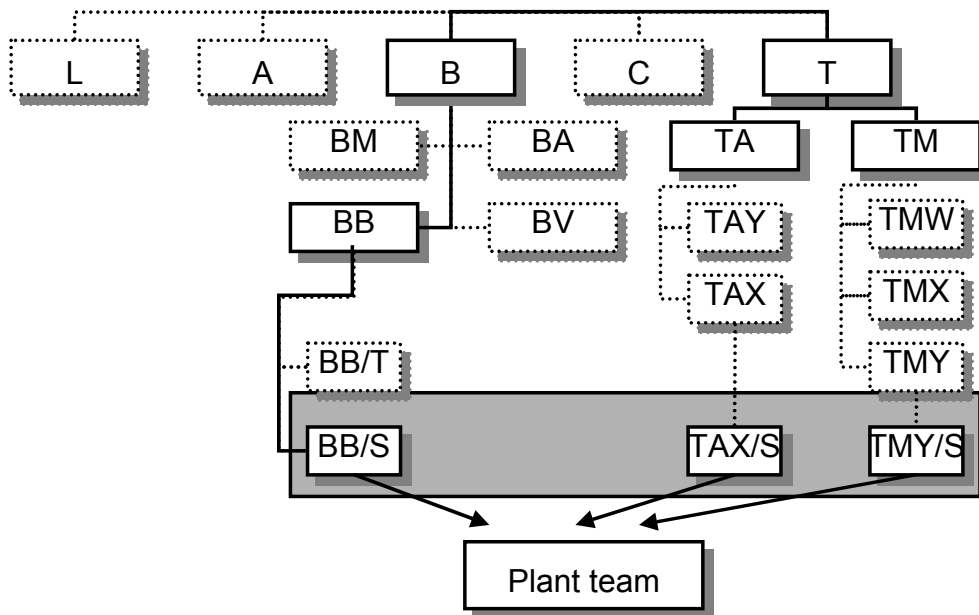

**Figure 8 The plant team.**

Together, the people from the management teams of B, TA and TM form the plant team. During our interviews, it was stressed that “this is very important at Company B.” (Interview NB, 28/02/01: 18) Before we discuss the functionality and the importance of such plant teams for organisational learning, let us first go a bit deeper into the structure of the composition of this plant team.

In figure° 8, we can clearly see the matrix form of the organisation structure. The people of TA(XS) and TM(YS) provide services to the steam cracker, but they don’t fall under the responsibility of the direction of the steam cracker. So although the people of TAXS and TMYS work ‘for’ the steam cracker, and only ‘for’ the steam cracker, they are not ‘of’ the steam cracker. They still reside within their own direction.

This calls for close consultation between these teams from the different divisions to keep everybody informed of what is happening at every instant in the entire plant. This is why this plant team plays such a major role in the running of the steam cracker.

This plant team meets twice a day, once in the morning at a quarter past eight and once in the evening at a quarter past five. At this morning meeting, the team leader or the assistant team leader, the foremen and representatives of the management of the plant are present. During this morning meeting, which lasts about fifteen minutes, the team leader on shift reports what has happened in the plant during the last sixteen hours. He gives an overview of how the plant is running, he explains which incidents have happened and whether any accidents have occurred. Then he goes over the production figures of that night. Next, any disturbances that have happened are discussed. After this discussion the plant team draws up a-to-do list by mutual agreement. This enlists all the

defects the operators have noticed during controls and that have to be fixed. It is of great importance that all three parties are present at this moment, because in this way, all the involved parties know what has happened, and which work they have to do and which tasks the other parties have to perform.

During the interviews, one of the operators gave an example of the interconnectedness of the work of the operators and TM and TA.

“With TM and TA, we also have a lot of consultation moments. For instance, when a pump breaks down, this pump has got to be rinsed out by the people of TM. But TA has then got to pinch off this motor, and they have got to remove the safety fuse in order to make sure that the motor will definitely not start. So for these things, consultation is absolutely necessary.” (Interview KDV, 03/04/01: 11)

In this way they can all gear their activities to one another. And finally, at the end of the morning meeting, there is still some time for announcements and questions.

At the evening meeting, all parties that are present during the morning meeting are also present during this meeting, but to a lesser extent. Of production usually the same persons are present, but of the technical department, usually one or two persons are. The evening meeting, which can last up to three quarters of an hour, is aimed towards the clearing of all the work permits. Here, the team leader of the shift is also the leader. He prepares these permits in the afternoon shift so the team leader has got to have a good view on which works are necessary for the day after. This entails the main part of this evening meeting. Then the people of the technical department, from TMYS and TAXS, present which works they have performed during the day, and which are still on the worklist. And finally, there is again some time reserved for questions and remarks. So at these meetings a lot of information is transferred between the different parties.

How is this all connected to the concept of organisational learning as used by the members of our research team? First of all, the way in which Company B is organised, with the technical department providing exclusive services to a production plant, makes these intensive meetings between the different involved parties necessary to keep everybody well informed. This information flow would otherwise not occur this intensively. But more important maybe, the structure of an independent technical department, which provides services to the steam cracker, provides a structure that stimulates learning and the transfer of knowledge within this technical department. Let us clear out this point.

Let us have a look at the situation in which the services TA and TM provide would be incorporated within the production plants. The division T would then be dismantled and the services that they provide would then be done within the production plants. Suppose we would not change the way in which the functions are composed right now. This

means that the job of an operator and the jobs of the technical maintenance and automation people would remain separate jobs.

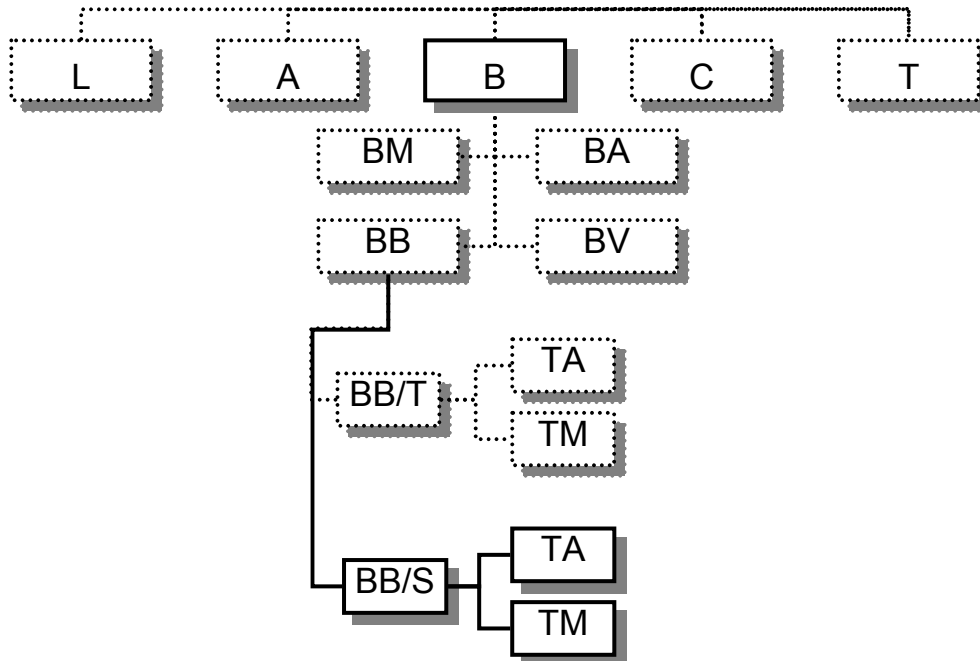

**Figure 9 Incorporation of TA and TM within the steam cracker.**

We can look at this as the incorporation of the now dedicated team of TAXS and TMYS within the supervision of the plant management of the steam cracker. The incorporation of the services which TA and TM provide within the organisation of the production companies would not change much for the meetings they have. This information flow would still be necessary and would probably be as intensive as is the case now. This would only be of influence on the relations between the management of the steam cracker and the management of technical maintenance and automation. Right now, the plant manager and company engineers of TA and TM are hierarchically at the same level, on the understanding that the plant manager of the steam cracker is the *primus inter pares*. When a final decision has got to be reached, he is the one who bears the end responsibility and who has got the last word. If not much would change, why then would we reckon that the structure as it exists today would be better for organisational learning?

If technical maintenance were to be incorporated within the production plants, these people would then lose their strong connection to a technical central division, which would remain operational for work, done at a central level. For instance, pumps that are used on the entire site, and which are not specific to one plant, could still be repaired at

a central level, as is the case now. How does this link of these technical workers with their own department affect organisational learning?

One of the criteria of organisational learning as proposed by our research team is that: “knowledge is being created within the organisation, at different levels and it is being shared within the organisation”. (Fisher & Röben, 2001: 137) It is just this knowledge creation and distribution that happens as a result of the specific situation at Company B. Although the people of TAXS and TMYS work only dedicated to the steam cracker, they still reside under the responsibility of direction T. So as we have stated before, although they work for the steam cracker, they are not of the steam cracker

Not only do these technical maintenance people from TAXS and TMYS have regular meetings with the people of the production side of the steam cracker, they also have meetings with people who do the technical maintenance for other plants. For instance the company engineer who works for TMYS has got meetings with his fellow engineers from other plants. The same holds for the assistant engineers and the foremen. And the workers are much more in contact with their colleagues who work for different plants. Since the building from where TMYS operates from is shared with other maintenance teams from other plants, this creates learning and knowledge transfers synergy this way. Problems which workers run into can easily be discussed informally with their colleagues who work for another plant, which can offer refreshing, alternative views on these matters from their own experience. This creates a forum through which new knowledge can be created by bringing together the knowledge of someone with similar experiences in another plant and the problem a worker experiences in maintenance of the steam cracker.

This aspect of organisational learning, where knowledge that is put to the organisations use is created and diffused within the organisation, is also formally acknowledged by Company B through the incorporation of Know How Verbund in their Verbund concept.

What we have tried to show you is how the organisation of Company B provides a structure that stimulates the creation and the diffusion of company oriented knowledge. We believe that these structural prerequisites for learning are of great importance.

### **Link to organisational learning**

The organisation of Company B provides a structure through which learning is stimulated and which allows for the flow of knowledge, which would not occur to the

same extent as outlined if maintenance would be incorporated within the steam cracker.<sup>19</sup> This case thus strongly comply with our first, second and fourth criteria.

This organisation has thus developed a structure through which learning and knowledge exchange is permanently stimulated, in a horizontal way and in a vertical way. How do we have to understand this latter element? Well, let us again take a look at the organisational structure of the steam cracker. We notice two parallel organised departments, where members of maintenance personnel work dedicated to the steam cracker and come together regularly with members of the steam cracker personnel. This coming together in the plant team can be described as horizontal learning and knowledge exchange. People from different production and maintenance come together in these meetings and exchange knowledge in these meetings and learn from each other.

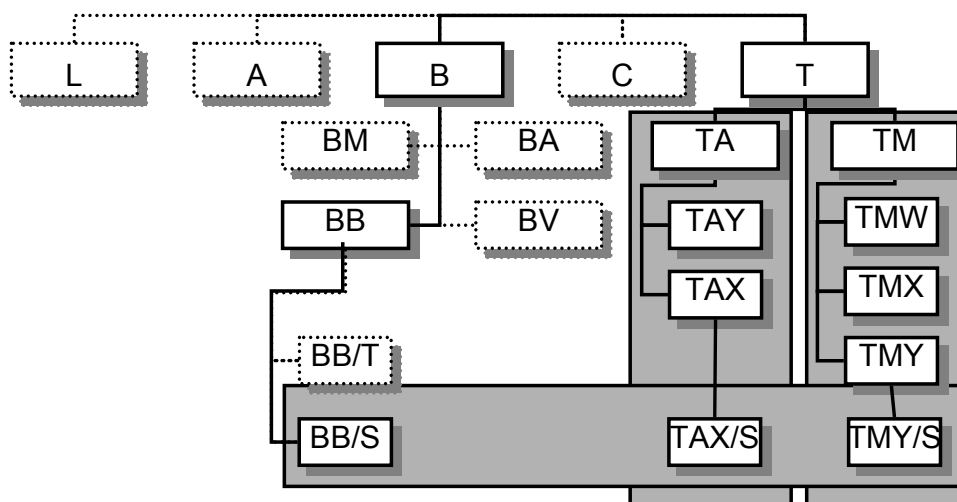

**Figure 10 Horizontal and vertical learning and knowledge exchange at the steam cracker.**

What we have called vertical learning occurs in the maintenance department. This is illustrated by figure<sup>o</sup> 10. These people work dedicated to the steam cracker but they are not of the steam cracker. Within TA and TM, there are a multitude of maintenance teams who work for certain plants, each with their own engineers, assistant engineers and foremen. These people from these different teams within TA and TM also have regular meetings, in which they exchange experiences about how certain problems are

<sup>19</sup> By this, we do not mean the integration of maintenance task within the function description of an operator. This initiative would of course structurally improve the learning possibilities of the operators and their scope of comprehensiveness of the steam cracker. The philosophy behind this idea is best explained using a figure of speech. You don't have to know how the engine of your car works in order to drive it; but if you know how it works, you will drive differently with it. But such an initiative has not yet been undertaken. By this integration, we mean the integration of maintenance personnel who now still reside under the responsibility of an engineer of TA and TM who would then reside under the responsibility of the plant manager of the steam cracker.

handled in other teams. And because the different teams of maintenance workers of TM all have a place in the central working place, they constantly meet maintenance workers from other plants with whom they can exchange experiences concerning problem solving.

We would like to point out that it is not the structure as such that we have looked upon as a case of organisational learning, but the way that this structure is filled in. The initiatives discussed, as the meetings between BBS and TMYS en TAXS, and the meetings among people of TM and TA, constitute the cases of organisational learning. Thus, the company's policy to ensure the interconnectedness of teams and persons by different means, can be regarded as one of our cases. As such, it is not the organisational structure in itself, but the way in which this specific matrixstructure has been filled in by the company, that is of importance for organisational learning.

## **2.7 Case 4: Handling of critical incidents**

Just after our preliminary interviews had taken place, we had been informed by Company B and the national media that a major disturbance had taken place at the steam cracker. (De Standaard Online, 06/03/01) Luckily, there were no injuries and production could be resumed soon after, although several parts of the installation had been damaged severely.

Although for Company B, this incident was a major setback, it provided us with a unique opportunity to study at a close range how an organisation tackles such a crisis situation. From our research viewpoint, this incident was especially interesting. We could, over time, follow the changes that had been made throughout the organisation as a response to this (major) disturbance.

This incident provided us with a lucky coincidence. It allowed us to see what part organisational learning played in the handling of the incident. What we are going to do now, is first to look at this particular incident, which happened during the night of the fifth of March 2001. What happened and what went wrong? Secondly we will have a look at how this incident was analysed by the people of the steam cracker and how the results of this analysis were transferred to the workers of the steam cracker. Finally, we will look at a few initiatives that have been taken concerning training and education as a result of this incident, in order to be better prepared in the future.

### **The incident of the fifth of March 2001**

On the night of March the fifth, a fire had occurred, which had been "caused by a broken oil pipe at the steam cracker, an installation that is used in processing naphtha and LPG. The oil dripped from the tube and caught fire because of the great heat." (De

Standaard Online, 06/03/2001) As a result, so we read on, a huge fire arose which the fire brigade of Company B couldn't get under control. Therefore the help of the Antwerp fire fighting team was requested and a crisis centre was set up. Eventually the fire fighters got control over the fire. One of the ovens however was seriously damaged.

At Company B, we were told a similar story but from a different angle. While the newspaper article focussed entirely on the fire, and treated the fire as the incident, we were told that the fire had not been caused by the incident itself, but by a malreaction of a few workers to the incident.

The origins of this incident are to be located in another plant we already encountered in a previous chapter about the organisational structure of Company B, namely Tankpark (BB/T). This plant stores and supplies the basechemicals to be transformed to the other plants. Apparently, the feedstock was shut down and instantly reopened again, without the steam cracker being notified of this action beforehand. Because of the flow-nature of processes, this created a cascading effect of things going wrong. Add a few malreactions of the workers to this 'snowball' effect, and what was a small, seemingly controllable incident in the beginning, soon led to a complete shutdown in a few instants.

### **Analysis of the incident at the steam cracker**

At the time of the incident, all people were called upon that could help. For crisis situations like this, a special plan has been devised that was operational at that time. This meant amongst others that the plant management is permanently present at the steam cracker in two shifts. Presently, there is no time for analysis of the incident. What was tried, was to stabilise the plant as much as possible in order to get it running as soon as possible.

“At that time, you haven't got the time to think about it.“ (Interview GVC, 05/04/01: 9)

In the days after, an analysis was made by the plant management of what happened and what went wrong, since this was not clear at the beginning. They analyze the incident by drawing up a kind of 'facts tree', of what went wrong where at what time. This way, possible causes are noted and looked at from different angles.

By drawing up such a facts tree, they have made use of recording methods. The actions of the workers are also being documented by letting the workers put their experiences during the failure down in writing. By using such a methodology, they have put all the pieces of the puzzle together and have worked their way up to the very beginning of the

incident. In this way, a report was drawn up of what had happened from minute to minute, in order to map all the failures.

So in uncovering this disturbance, all the workers on shift were actively involved in helping to map out what went wrong. Of course, also a normal incident report had been drawn up for this incident, as is the normal procedure. But extra actions followed in order to prevent such incidents from happening again. The plant manager told us:

“Such an incident is run through with the team who has gone through it, to make sure this team knows which mistakes were made and how to react in the future. It becomes harder to get all the information to seep through to the other teams. But therefore we have got a system of incident reports, which are sent to all four teams. (...) Sometimes it is hard to get the finesse into a team. We have had a fairly big disturbance now, so I think I will go through this disturbance separately with all the different teams. The incident was so big, I want to go through it orally with each team. And to put all this experience in one incident report is also fairly difficult.” (Interview FW, 05/04/01: 12)

From the management point of view, a shut down is undesirable. For the education of an operator, a shutdown and the subsequent start-up provide a fabulous training, where in a few weeks, they can learn more about the plant, then in a year when the plant is running smoothly.

“Actually, it is the best way of learning for us. When the plant shuts down unplanned, this is bad for the company, but it is brilliant for us. I mean, you have got a bigger margin to work within because you are already out, and you have to do everything from scratch (...) which is the best lesson you can get.” (Interview FVDB, 03/04/01: 9)

So the operators look upon an incident as an ideal learning moment, because during a disturbance, experiences can be acquired with situations that only rarely happen, yet which are vital. The viewpoint of the management is a bit different. They also regard an incident as a learning moment, but not so much during the incident itself but more afterwards. As the plant manager told us:

“If you encounter a disturbance, and you have lost your capacity for two or three weeks, my first reaction is not: ‘Ho, ho, this is a good learning moment’. No, at that time, we are in sackcloth and ashes, and we curse. Then we say: ‘Damn, how could this have happened to us again’. Afterwards, when the plant is running again, you can say: ‘Now I want everyone to know what went wrong there.’ Then you begin to look at that incident from a different angle, and you start to treat it more like a learning moment. But at the moment when we are in it, we don’t say: ‘Well done men, we have trained our men well’.” (Interview FW, 05/04/01: 13)

We have already stated that some unfortunate reactions of some operators made the incident escalate even more. In order to still be able to look upon disturbances as learning possibilities, it is essential that no individual guilt is attributed.

### **Automation paradox**

In the description of the competence management at the steam cracker, we have already referred to this paradox when we discussed the process understanding as an essential competence for a worker. In the highly automated working environment of the steam cracker, the operator barely has to intervene when the process is running smoothly. However, in case of a disturbance, he has to be able to detect errors fast and accurately, to diagnose them and to fix them. (Sels, Van Hootegem, 1993: 172) His labour becomes a stochastic event, an unpredictable and unstandardizable event. But the more the plant becomes automated and the less disturbances occur, the less experience an operator can acquire in order to learn how to handle a disturbance.

Thus because of more automation, he loses his 'feeling' for the process, which is crucial for a good intervention in case of a disturbance. Although it may seem that through more automation the human factor becomes more obsolete, the opposite is true. The human factor is very important in response to a disturbance. This is what constitutes the paradox. Because of more automation, you have to rely more on your worker when something goes wrong. And furthermore, because fewer disturbances occur because of more automation, he is not able to acquire the essential skills of reacting adequately in case something goes wrong. More automation is thus not always beneficial for the company, especially not in case something goes wrong. This is what the automation paradox shows.

Continuous knowledge transfer, regular practice of the required skills and permanent socialisation must allow for the knowledge, skills and attitudes to be kept up to date. This is where the process simulator, as it has been installed at the steam cracker, can play a very important role.

This simulator is a separate console in the control room, which looks and responds just like an actual console, except for the fact that nothing changes for real in the installation itself. A computer program simulates the responses of the installation outside on the console. Workers can acquire experience with disturbances through simulating disturbances on this separate console. But as one of the workers reports: "We have used the simulator frequently during the start-up of the installation. Afterwards it has been used less often, because it is a bit outdated". (EDB, 29/03/02: 6) At the moment, management is re-evaluating the usability of this simulator, because of the high expenses of keeping the simulation programme up to date.

According to us, against the background of the automation paradox, the simulator can play an essential role in updating the skills needed to deal with a disturbance.

### **Initiatives**

In this part, we will look at which initiatives have been taken as a result of the disturbance. There for we went back to the steam cracker and had a follow-up interview with the assistant plant manager.

Besides numerous technical changes in the plant itself, two other changes are of importance to us.

An obligatory plan for training at the steam cracker has been drawn up for new workers during their first year at the steam cracker.<sup>20</sup> This plan consists out of two different modules. A first module, which already existed, is presented to the worker during the first six months.

“This module contains general things, which are very relevant. That is something we have experienced during the disturbance.” (Interview NB, 05/09/01: 1)

This existent module has been expanded upon with a second module, which runs from month six until twelve. This module contains practical questions related to key issues at the steam cracker. These questions are meant to be used by the novice worker to improve his comprehension of the site. They are thus not regarded as a test. With these two modules, the management of the steam cracker tries to “improve the availability of the workers, by providing them with a similar basis after one year.” (Interview NB, 05/09/01: 2)

A second initiative concerns the evaluation of a worker. Previously, this evaluation was only done by the team leader, and management was almost not involved. After six months, a newcomer has now also got an evaluation by the plant manager. During this conversation, the plant leader also asks for knowledge acquired during the first module. This is not conceived of as a kind of test. Furthermore, when someone has finished with a specific console (cold I, cold II and hot/auxiliary), there is also an evaluation of his work by the plant manager. It was stressed upon that this is not a test, just a way of finding out what the worker’s strengths and weakness are and how to improve on them.

### **Link to organisational learning**

This case shows us the measures this company has taken after something has gone seriously wrong. Several technical measures have been taken which Argyris and Schön

---

<sup>20</sup> This education plan is only for new workers who begin at an Aa-level. New workers who start at the steam cracker, but who have got experience in the chemical industry usually begin at a higher level.

would call single loop learning. But we can also observe a higher order of learning in this case, namely that of more fundamental changes in trying to get all the different learning cultures of the different teams aligned, by participating in the evaluation process of workers, and by providing feedback. Thus trying to establish a cultural transformation between the teams. The new way of registering competencies can also be interpreted in this respect.

Furthermore, just the fact that these changes take place as a result of the incident, could be regarded as organisational learning. The work routines have been evaluated as a result of the incident, and changes have been made, thus the organisation has learned from this experience. This incident has been discussed in detail with the different teams, and this incident has been and will be the subject of several project meetings at the steam cracker. So a lot of knowledge is created and shared. And since two experts from another department assisted the people of the steam cracker during the audit of the incident, we can also say that learning from the environment has taken place. All this information has also been conveyed to the people of the steam cracker in Ludwigshafen, thus stimulating organisational learning.

## **Conclusion**

In this paper we have presented you with a concise theoretical framework. Then we have presented our four different cases of organisational learning. The danger is of course that these cases are looked upon independently from each other and are regarded as four separate cases. This could lead to misunderstanding, since these cases are of course strongly interrelated. This paper should therefore be looked upon as a whole, with all cases intertwined. That is why we present you a conclusive matrix in which all cases are presented according to our five criteria of organisational learning.

Table 5

Criteria	Work routines	(In)formal learning	Cultural transformation	Knowl. creation & sharing	Environment
Reevaluation of SOP					
Plant manual					
Suggestion					
Idea manager					
Incident report					
Grey booklets					
Competence management					
Organisational structure					
Handling of critical incidents					

## References

- Berger P. & Luckmann T. (1966), *The social construction of reality*, Doubleday & company, New York.
- Boreham N. et al. (2001), 'Criteria for organisational learning', in M. Fisher & P. Röben (eds.), *Ways of organisational learning in the chemical industry and their impact on vocational education and training: a literature review*, ITB-Arbeitspapiere, Bremen, p. 131-138.
- Company B (1999), *Social report 1999*, Company B
- Fisher M. & Röben P. (eds.) (2001), *Ways of organisational learning in the chemical industry and their impact on vocational education and training: a literature review*, ITB-Arbeitspapiere, Bremen.
- Huysmans M. & van der Vlist (1998), 'Naar een 'organisational learning benadering van de lerende organisatie', *Gedrag en organisatie*, jrg. 11, nr. 5, p. 219-232.
- Huys, R. (a.o.) (2001), *The delayed transformation: Technical and socio-organizational restructurations in the chemical, automobile and machine-tool industry*, Departement Sociologie
- Mariani M. (2001), 'Organisational learning: towards a unified view of individuals, work and society', in M. Fisher & P. Röben (eds.) (2001), *Ways of organisational learning in the chemical industry and their impact on vocational*

*education and training: a literature review*, ITB-Arbeitspapiere, Bremen, p. 65-81.

Nonaka I. & Takeuchi H. (1997), *De kenniscreërende onderneming*, Scriptum, Schiedam

Sels, L. & Van Hootegem G. (1993), 'Tweesprong. Over droomfabrieken en hun maatschappelijke inbedding', in W. Dumon e.a. (eds.), *Scenario's voor de toekomst*, Acco, Leuven

Snyder W. & Cummings T. (1998), Organisational learning disorders: Conceptual model and intervention hypotheses, *Human relations*, vol. 51, n° 4, p. 531-546.

X (06/03/01), Brand bij Company B Antwerpen, *De Standaard online*

*Peter Röben*

### **3 Cases of Organisational Learning in Company G (Germany)**

**A case study of organisational learning in two plants and a department of initial and further education.**

#### **3.1 The approach of Company G to organisational learning**

Company G is a transnational chemical company that, in its own words, “aims to increase and sustain its corporate value through growth and innovation”. The company's product range includes high-value chemicals, plastics, colorants and pigments, dispersions, automotive and industrial coatings, agricultural products and fine chemicals as well as crude oil and natural gas.

Company G's approach to integration, known in German as "Verbund", is one of its particular strengths, enabling cost savings and a competitive advantage. With sales in 2000 of EUR 35.9 billion and a workforce of 100,000 employees, it is one of the world's leading chemical companies.

The product line of Company G comprises high-value-added chemicals, plastics, colorants and pigments, dispersions, automotive and industrial coatings, crop-protection agents, fine chemicals, oil and gas. The range of over 8000 products can be divided into the following 7 sectors:

#### **I Agricultural Products and Additives for Nutrition and Cosmetics Industry**

Company G offers crop protection systems for reliable yields, a broad range of additives and processing aids for nutrition of humans and animals and products for the cosmetics industry. It offers its agricultural customers a range of herbicides, fungicides and insecticides. Company G produces vitamins, carotinoids, and nutraceuticals as additives of foods and polymers and active ingredients for the cosmetic industry i.e. sunscreens, emulsifiers, active ingredients and vitamins for skin care and fragrances.

## **II Pharmaceutical chemicals for the pharmaceutical industry**

Company G supplies the pharmaceutical industry with high-quality active ingredients and additives used to optimize pharmaceutical properties, as well as functional auxiliaries.

## **III Performance Chemicals for the leather, textile and print industry**

Company G offers organic and inorganic pigments for a wide variety of industries that give the colour to architectural finishes, industrial and automotive coatings, plastics, printing inks and ceramics. A field with an old tradition of customer relations are the leather chemicals: the chemicals and colorants for the leather industry result in highly wearable clothing, fashionable and sturdy shoes, bags and accessories, high-quality car seats and comfortable sofas.

## **IV Coatings**

Colour paints produced by Company G Coatings are used as vibrant factory finishes by many of the world's leading automobile makers. Conventional paint systems keep getting better, but the real focus is on ecoefficient powder coating and water-based technologies. Many other products, like home appliances and industrial equipment, are protected by industrial paints.

## **V Petrochemicals and plastics**

Products produced in Company G's steamcrackers (two of them are enclosed in our investigation), like ethylene and propylene, are at the beginning of many value-added chains. Company G's broad range of plasticizers lend tailor-made properties to plastics. Oxygenated, halogen-free Company G solvents are essential to the production of many pharmaceuticals, paints and cosmetic products.

Company G produces a broad range of plastics, i.e. Polystyrenes are used everywhere: as packaging materials or containers, and in a wide range of appliance and equipment housings.

## **VI Inorganic Chemicals**

The raw materials ammonia, chlorine and sulfuric acid play a key role in many production processes. Sophisticated Company G catalysts increase the efficiency of processes. With its formaldehyde, melamine, glues and impregnating resins, Company G is a business partner to the wood products and paper industries. In our case study, we introduce the sulphite-factory of company G, which provides additives for the photo and food industry.

## VII Intermediates

Company G intermediates often play a key role as reactants in the numerous process steps used to get from a raw material to a finished product. Amines, diols, carboxylic acids, carboxy intermediates and dyestuff intermediates, as well as intermediates for fine chemicals - some 550 compounds in all - are available to the customers. They are used to manufacture plastics, textile fibers, colorants, pharmaceuticals and crop protection agents. And Company G is always developing new intermediates in close collaboration with its customers – trying to create intermediates that are tailored to meet customer needs.

Company G sales reached EURO 35.9 billion in 2000 and had about 100,000 employees worldwide, operates production facilities in 38 countries and maintains contact with customers in more than 170 nations. It invested over EURO 1.5 billion in research and development in 2000 and is among the top five companies in Europe for patent applications. Company G submitted 1,110 patent applications worldwide in 2000. Currently it has just under 110,000 patents and patent applications.

The integrated network principle, the "Verbund", is instrumental in Company G's success and it belongs to their identity. At Company G's Verbund sites, the various plants are integrated with each other. This translates into a more efficient and resource-saving utilization of raw materials and energy in all chemical processes. Moreover, transportation distances are kept to a minimum, while the logistics and infrastructure are jointly employed to great advantage. The synergistic effects in the Verbund help save the environment and save money as well, according to information from company G, some EURO 500 million per year in the biggest site alone.

In its self-portrayal Company G say that responsibility towards the environment and towards society are key elements of their corporate philosophy which is based on the principle of sustainable development. The company has subscribed to the "Responsible Care" initiative launched by the chemical industry.

### **Company G and the concept of learning organisation**

What are the reasons why company G has chosen the concept of the learning company? The answer for that has to include the following four points:

1. In the near future Company G wants to keep or reach the leading position in many regional markets all over the world in spite of increasing competition.
2. Company G globalises its production by building new headquarters to supply important regional markets in the USA, South America, Asia and Europe.

3. Company G changes its organisation gingerly by abandoning the ideal of a centralistically lead and hierarchically co-ordinated company and aspires to several new business units: Regional Business Units and Global Business Units.
4. Company G establishes a working atmosphere where the potentials of *all* employees are developed and used for the benefit of the whole company.

#### Reference 1.

In the last years Company G has concentrated on its core competence in industrial chemistry and has withdrawn widely from consumer markets. That way their own pharmaceutical part that had been concentrated in a company of its own was completely given up and sold. Instead company G entered the oil and gas business and provided itself that way with its own raw material and energy basis.

The potentials of compound chemistry are greatly exhausted by the 7 sectors of chemical production mentioned above. In addition, the company gains a relative independence of the cyclical fluctuations that are especially important for a location with several compounds by the diversification of the industrial clients. The advantage of a location with several compounds like the effective utilisation of energy, raw materials and inter-products can only be realised if the amount of production for all chemical production units involved is relatively high. Because the production of a multitude of chemical products in the industrial compound is so closely interconnected, a reaction to the market situation in different markets can only be a little flexible. Because the produced quantity of a product can only be increased within small limits while the quantity of another product is reduced and the costs are held on a low level at the same time. The compound production depends therefore on relatively stable markets if the advantages of this kind of production should be completely exhausted.

The market leadership can, for example, be reached with a leadership in terms of costs. Company G reduces costs with highly automated modern plants that are rigidly integrated in the compound. Another possibility to reach the market leadership is obtaining the leading position in quality, which also refers to very modern plants. Closely connected with that is the ability of innovation in the company: Since the very beginning of the chemical production, chemical companies could only grow by offering permanently new products with qualities attractive for their customers and by always being one step ahead of their competitors. Beside the permanent improvement of the technical basis, permanent research on a high level is needed that includes both basic research (e.g. genetic engineering in the scope of agricultural research) and applied research (e.g. testing new found substances for their qualities during several conditions of production in the leather industry).

## Reference 2.

The company G came already into existence as an integrated network company (Verbundstandort) in Germany and has one of the largest locations of chemical production world-wide there. During the last decades, additional integrated network locations have been added not only in Europe but in America and Asia, too. In these locations plants are build up on the latest technical level and some of them (e.g. steam crackers) are substantially larger than in Germany. The knowledge accumulated during decades out of the slowly growing location in Germany is here systematically applied and results in plants that are substantially more effective than in Germany. In the chemical industry a remarkable increase in effectively is reached by increasing the size of the chemical plant. The existing plants in Germany cannot simply copy this efficiency reached by size and modernity, because an existing steam cracker cannot be simply be brought up to scale. Nevertheless, all steam crackers of the world are evaluated in the Solomon-study with the same economical criteria. Bad rankings in such a study cause more need for explanation through the works manager than good rankings. The new integrated network locations produce admittedly for other markets than the German one but all locations are put into a competition with each other by their economical key-data. In such regard the central integrated network location appears worse than locations outside Germany, which manifests itself in a decreased bonus for the staff of the central location in 2001. The message about the decreased bonus was spread at the same time with the message about the increase of the stock yield which lead to the largest protest movement on the site of the company G since the company came into existence: Over 15000 employees marched to the management building to express their overwhelming displeasure.

The displeasure of the employees is also caused by the opinion of the employees that the location in Germany fulfills extensive service functions for other locations, which are not shown in the company's calculations. The know-how transfer from Germany into other locations leads to improved competition conditions there, which makes a significantly negative difference here in Germany. The question is who profits from a learning company which distinguishes itself by successful knowledge management, becomes most current. The exchange of knowledge and experience within the company will be stoped as long as the employees do not see the benefit for themselves but rather only for the company.

## Reference 3:

Company G has imposed an extensive organisation-development program on itself, which is internally and externally carried along under the name "Fit for the Future".

Basically, the program is about a cautious de-centralisation in global business units (GBU), regional business units (RBU) and service platforms. Since this program has just started the effects cannot yet be valued in this study. The goals of “Fit for the Future” are widely unknown, even in the company; therefore, it can be seen as a test for the learning company. According to the conception of a learning company it should succeed not only in making all goals of the management transparent to the staff, but also in conceding the staff possibilities of participation in the shaping of the company and its further development.

#### Reference 4.

For a learning company to be able to unfold its possibilities a development of a learn-culture and culture of cooperation is necessary, which poses big challenges in particular in the German chemical industry. Especially in the big companies which are engaged in the production of basic chemical substances changes of organisation were relatively seldom. Hierarchical structures and authoritarian behaviour have not died out yet. But it is a contradiction to encourage the employees on one hand to participate in further development of the company, hence to address them as equal partners in the company, and on the other hand to cultivate a climate of control hierarchy and dominance by superiors. To establish a communicative climate Company G has formulated a vision for all members of the company that have their specific characteristics for different departments of the company. Concerning the involvement of the employees it is formulated:

„The motivation and qualification of employees are exemplary. This means we ensure that accountability, team orientation and willingness to handle a wide variety of tasks, along with operational and international experience, are qualifications embodied by our employees.“ (Vision 2010)

It can not be a demand of the management to force the employees to have the motivation to further develop the company and themselves. Motivation, like trust, is not enforceable but has to be developed and promoted by the actions of the management and by organizational measures.

To what extent Company G succeeds in putting the concept of the learning company into practice in these four fields should be clarified with the following case-study that involves three departments of the company: The steam cracker, the sulphite factory and the education of the company. All of these are introduced in the following five cases of successful or less successful organizational learning and conclusions have been drawn from them.

## The fields of the empirical investigation

### The steam cracker in Germany

The steam cracker is a relatively large chemicals plant with two complex and large-scale production plants (Cracker 1 and 2). The workforce comprises a works manager, 2 deputy works managers, 2 works assistants, 6 day foremen and ten other day-shift workers. There are three shifts, each with its own shift manager responsible for the plant. Each shift is comprised of two groups, one for each plant. Each shift is led by a foreman and his deputy. At each plant, in addition to the shift manager and his deputy, there are also four workers per shift who are viewed as managerial staff on the shift. In each of the shifts, these managers comprise different numbers of operators<sup>21</sup>(O), foremen (FM) and section leaders (SL). In total, there are 164 workers, of whom 6 are apprentices.

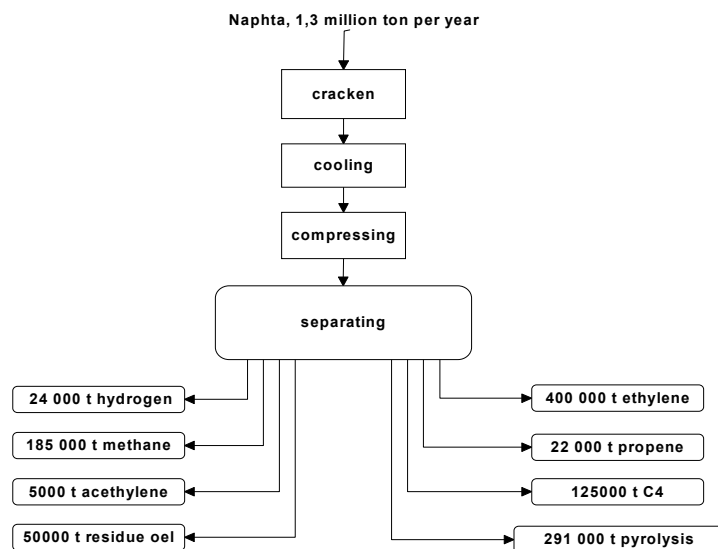
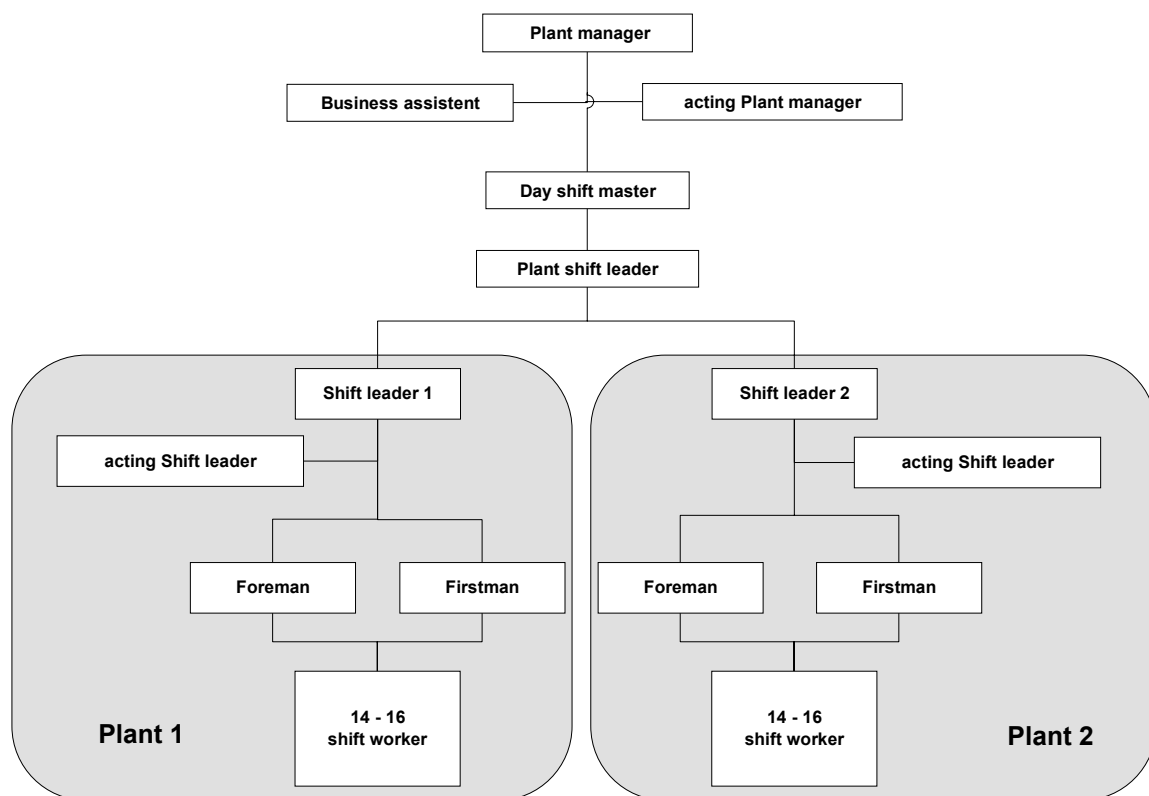

**Figure 11** Flow scheme of the steamcracker. The starting point is naphtha, a raw fuel. The process step cracking is needed to break big organic molecules in a gas phase into smaller ones. For this high temperatures are needed and this process is carry out in a big ovens which heat the raw fuel up to 850 °C. At this temperature small molecules are much more stable then bigger ones. The cracked naphtha molecules are embedded in steam, which condense back to bigger molecules when the gas is cooled. To separate the many different molecules a lot of process engineering columns are needed, which are working at very low temperatures because it is necessary that the gas from the previous process is converted into a liquid. To achieve this the gas must be cooled and compressed.

The boundary conditions under which the organisational processes at the steam cracker in Germany can be evaluated and refined are greatly influenced by the specific

<sup>21</sup> An 'operator' at Company G is someone who has successfully completed the first half of his or her *Meister* training. In other companies besides Company G, the term operator refers to a normal shift worker working with the process control system (control room operator) or in the plant itself (field operator). Company G does not have this division of labour: every shift worker is supposed to be skilled in both these areas.

characteristics of these large-scale chemical plants. The steam cracker is the starting point for a chain of chemical production stages and outputs the first intermediate products (mainly ethylene and propylene) which are then delivered to other chemical plants at the site of Company G and to the ethylene network system in Germany. As intermediate products, ethylene and propylene have to go through further production stages before they are made into the many synthetic materials that Company G produces. The steam cracker produces on a continuous basis and is able to vary its production volumes or products within narrow limits only.



**Figure 12 Organisational chart of the steam cracker. Two plants are integrated into one organisation.**

The various activities performed at the steam cracker can be classified along horizontal and vertical lines (in terms of different line organisations or levels of hierarchy, respectively).

Table 6

Level of hierarchy Operations	Main responsibilities Operations	Level of hierarchy Plant Engineering	Main responsibilities Plant Engineering
Works manager	Compliance with financial targets, integration at section level, supervising day foremen and shift foremen; plant optimization	Works engineer	Detail planning and realization of plant modifications, supervising implementation
Day-shift foreman (DF)	Availability of production plant: planning and organizing activities to maintain, improve or restore operation of the production plant	Foremen in the various specializations (e.g. Mechanics/Process Engineering; Control Engineering;	In consultation with the day foremen: planning and organisation of detail measures on the production plant (e.g. pump changes); procurement of spare parts; coordination of external contractors
Shift (workers and shift foremen (SF))	Operating the production plant: running the plant; tracing and reporting faults, decommissioning parts for repair and recommissioning after repair, instructing tradespersons	Craft tradespersons in the various specializations	Implementation of measures (e.g. dismantling and installing pumps)

Related to the goals in the examination, it is important to know that the requirements on the work force result from the handling of a technological process in a great scale. Safety for the (employees) work force and for the surrounding cities is most important.

The steam cracker is a plant under a constant change. Every day components of this big plant are exchanged. The reasons for this are various, but above all, it is natural wear. If a pump reaches its wearing limit, it has to be exchanged, and if damages occur at the pump, control unit, valve, turbine etc., the change is also necessary. The workforce at the steam cracker is responsible for detecting all the parts that have to be repaired or to be exchanged, and is also responsible for all necessary measures for the preparation of the concerned parts of the plant. The repairing and the exchange of components of the plant are in the responsibility of craftsman of the maintenance department, the biggest department in the whole company.

Two main fields of duty for the employees of the steam cracker can be identified:

- Operation and supervision of the facility
- Maintenance conversion and change of structural parts of the facility

These tasks can on the one hand be assigned to the shifts and on the other hand to the day shift. The shift primarily operates and supervises the facility and is in addition responsible that the maintenance work in the facility is prepared, seen off and post processed. The preparation consists of taking the parts of the facility that are to be repaired out of service and cleaning them. Seeing off consists of regular checks and controls of the working permission of the mechanics by the foreman. To bring the parts of the facility that had been taken out of service back in service, subsequent to the repair, is part of the tasks of the shift.

The day shift is responsible that the availability of the facility is optimal. Thereto belongs the planning and preparation of larger maintenance measures together with the corresponding departments of engineering of the company. Under supervision and in cooperation with the management of the company and the company's engineer the optimization of the facility is practiced by extending and reconstructing whole facility parts.

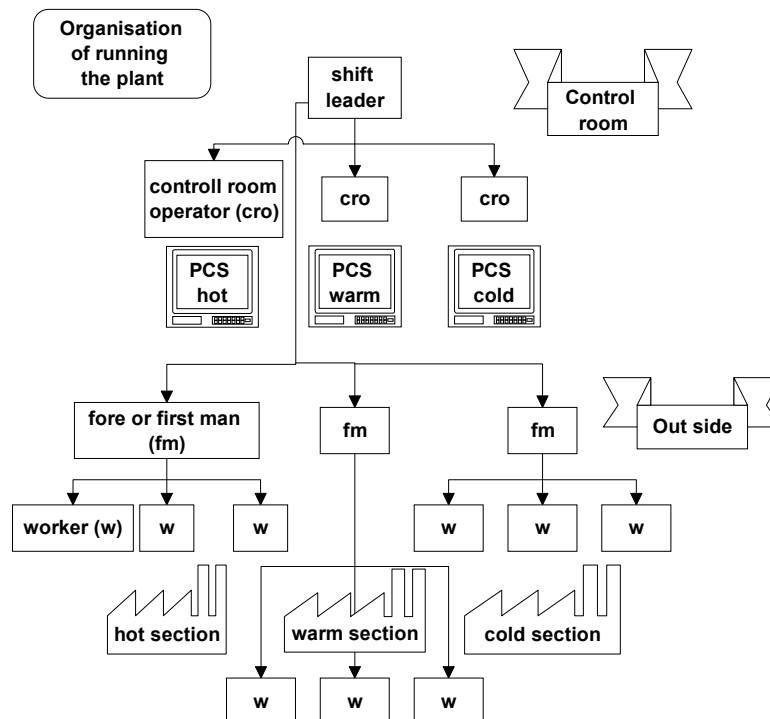

**Figure 13 Organisation of running the plant.** The plant is controlled by a process control system (PCS) in a control room. The whole plant is divided in three sections: hot section is the oven in which the naphtha is cracked. The warm section is the part with the cooling and the compression equipment. The cold section is the separation part with the columns. In the control room are three control room operators, one for each section. They are in intensive contact with groups of workers who work outside and are lead by a foreman. In this configuration the work is done if, for example, a bigger apparatus (pump, valve, centrifuge etc.) has to be exchanged. Individual workers can work as control room operators as well as outside in the plant. The management and the shift leader want as many workers as possible able to work both inside and outside. But no-one is forced to use, for instance, the PCS.

This rough distribution of tasks cannot be absolutely decided. It is one of the main tasks of the day shift to optimise the installation but the shift is expected to participate in optimizing the facility, too. The management wants the shift to make suggestions for improvements.

The interface between the engineering department of the company and production in company G is organized in Germany and in the Antwerp location (see explanations in the case study in Belgium) in a similar way. However, the location in Germany is

approximately 7 to 10 times larger and the corresponding facilities are accordingly further divided. The engineering department of the company, with a staff of approximately 10000 people is the largest department in the Company G headquarters . Between this department and the plants exist specific points of inharmoniousness and the endeavor to ease these points of inharmoniousness.

EXAMPLE: a special workshop was conducted in the steam cracker that focused intensively on the interface between operations and the plant engineering section. The topics covered the division of labor between the steam cracker personnel and the plant engineering staff, on the one hand, and the optimization of day-to-day collaboration, on the other. Participants from both parts of the organisation took a day and a half's time, away from daily operations, to discuss problems relating to how they work together. In response to ideas generated at the workshop, the joint meeting of steam cracker workers and the foremen from the plant engineering section (the so-called 'morning group') was split into two separate meetings (a large meeting with the works management and a small meeting of foremen).

The workshop could be interpreted as an element of organisational learning if its convocation were firmly established in the rules of the organisation, i.e. if the organisation has implemented procedures for its own improvement. There is an organisational procedure within Company G that enables workshops of this kind to be organized. The procedure is called '*Treffpunkt i*' ('Meeting Point i') and is equivalent to a quality circle. Employees are supposed to collaborate in a '*Treffpunkt i*' team for at least a year. The spokesman of such a team is trained for this task by the continuing training department. The steam cracker – plant engineering workshop has been a singular event until now, so it is not a '*Treffpunkt-i*' meeting, although it could become the starting point for one.

An additional workshop was held in the steam cracker with the aim of analyzing weaknesses on the part of participants. Topics addressed included management style, specific problems arising, organisational deficiencies in cooperation with other parts of Company G and problems relating to work procedures. But it seems that this workshop is a singular event also.

At the foremen/engineer level, there are teams for certain technical problems. The composition of these teams depends on the type of technical problem they address.

In the steam cracker, a case of organisational learning was identified: The participative making of a plant manual and its integration in a qualification system. (See p. 77).

### The sulphite factory

The sulphite factory is a small site compared to the steam cracker, with relatively simple continuous production of chemicals (sodium disulphite, sodium sulphite, sodium bisulphite solution, potassium sulphite, potassium sulphite solution). Work force consists of altogether 40 persons: 1 works manager, 2 day foremen, 4 shift foreman, 5 employees on the day shift, 28 shift workers in 4 shifts.

Sulphite are chemical substances used as additives in the food, photo chemical processes, paper, dye and building material industry. For instance sodiumbi- and sodiumdisulphites used as preservative E223 or E222 and potassiumdisulphite as E224 (i.e. in wine) (purity level: food grade). These substances are also used (purity level: photo grade) in the Photo industry in developing and fixing baths.

Sulphites have been produced since 1890. Sulphites are substances that are made out of products that typically accrue during the production of sulphuric acid. In 1912, for example, the “Bisulfabrik” drew roast gas from the sulphuric acid factory and produced with that gas bisulphites. Which are by-products in the sulphuric acid factory, they can hardly be used in further production, but are an important raw material for the production of sulphites.

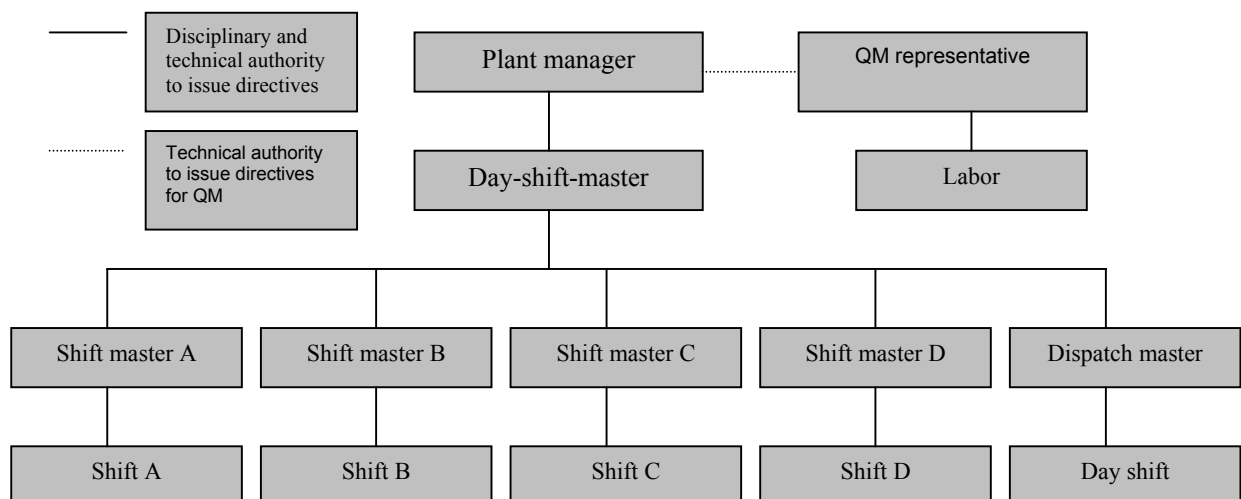

**Figure 14 Organization chart of the sulphite factory.**

The capital equipment has a high degree of automatization and represent the state of the art in their field. The embedding in the network of Company G still happens today by the supply with SO<sub>2</sub> from the sulphuric-acid factory. In addition, the factory gets NaOH from the neighboring electrolysis factory and produces the sulphites essentially without waste by-products. 90% of the production is for the market and 10% (ca. 10000t) for

consumers of the German production site. The consumers are either connected by pipelines or receive the sulphites as bulk material in sacks, containers or big packages.

The production of substances used in the food and photo industry led to the introduction of a QM-system in the sulphite factory, in 1991. In 1994, there were the first internal audits and in 1995, the factory was certificated according to DIN ISO 9001 and fulfills the requirements of the GMP (food industry). Company G is the largest producer of sulphites world-wide and is the market-leader in Europe.

The comparably small number of employees (less than 40) implies that specific tasks organized specifically in larger factories are done here, for example, during the shifts. For instance:

Some tasks are performed on the shift that could be considered those of a quality circle. The quality of sulphites is determined with the whole range of parameters that determine product quality (e.g. purity of product, specification of foreign matter). If these parameters deteriorate and approach the limits of the predefined specifications, the shift discusses what the causes might be. As in the steam cracker, there are morning meetings in the sulphite factory with the foremen responsible for measuring and regulation systems, for control engineering and for process engineering/mechanics. These morning meetings also discuss possible causes of impaired quality. This can be interpreted as communication on the performance of the factory.

Safety instructions relating to First Aid, respiratory equipment, oxygen equipment and handling chemicals are systematically organized and stipulated. There is also safety training for fork-lift drivers. Foremen receive additional training in health and safety at work and environmental protection I and II. Quality directives are also described in the quality management system for every workplace in the factory. A comparison with the actual skills of the job holders enables training needs to be ascertained. The satisfaction of these needs must be documented in the quality manual for the factory. There is strict compliance with the quality system for the factory, but we did not observe any discussion and reflection about the rules laid down by that system.

There is a familiarization plan for new employees and checks are run to ensure compliance with the plan. Each new employee has a sponsor who is there to help him overcome any initial problems that may arise. The sponsor is responsible for supporting learning progress and approves certain training measures for the new employee with his signature.

The company is under an obligation – as an off-shoot of the quality system – to draw up a training plan for every single worker. Each workplace and the skills required for it is defined in the quality manual. When this definition is compared with the skill profile of

the worker who fills the position defined in the quality manual, a skill differential results that has to be reduced in the course of time. Another requirement is that a succession plan has to be drafted for those workers who will be retiring in the near future.

### **The department of initial and further education**

The initial and continuing training division (Company G abbreviation: GPW, G=Global, P=Personnel, W=Education) is organized into four sub-divisions, namely Initial Training, Continuing Training, Personnel Management and Service Centre (see organisational chart next page).

The division has approx. 360 staff. The biggest department is Initial Training. In 1998, Company G had a total of 2631 apprentices and trainees, of whom 1130 were training for technical occupations (e.g. electronic engineers for process control, industrial mechanics, plant mechanics, power electricians, etc.), 955 in the so-called science occupations (chemicals operator, chemicals laboratory technician) and 480 in commercial occupations.

The company training system was reorganized in 1998. This organisational development, which will last until the end of 2001, is called the 'Focus' project. In the course of the Focus project, there has been a reduction in the number of training staff from 420 to 360, as well as repositioning for greater market focus and a shift away from field-based training to a training system centred on processes and on providing guidance to apprentices. For example, training in the various industrial-technical and commercial occupations has been subsumed under a single management, while all continuing and further training has been concentrated in a single organisational unit. The business process of the division has been organized into core processes and support processes. Examples of support processes are booking hotels for courses outside the company, or technical support for laboratories. Core processes are those services performed by the training division that are paid by the respective customers, namely the other Company G divisions. These services include seminar courses and projects, for example.

Projects are a relatively new service performed by the training division. The first step in a project involves employees compiling the training and skills needed for a production site. Once needs have been determined both qualitatively and quantitatively, a special training scheme specifically addressed to those needs is offered by the training division. This can involve a standardized seminar adapted to the particular needs of the enterprise, or a training scheme that has been developed from scratch. The project for participative production of the plant manual (see case study 1) is an example for such a newly developed scheme on the part of the training division.

Figure 15 Organization chart of the department of initial and further education.

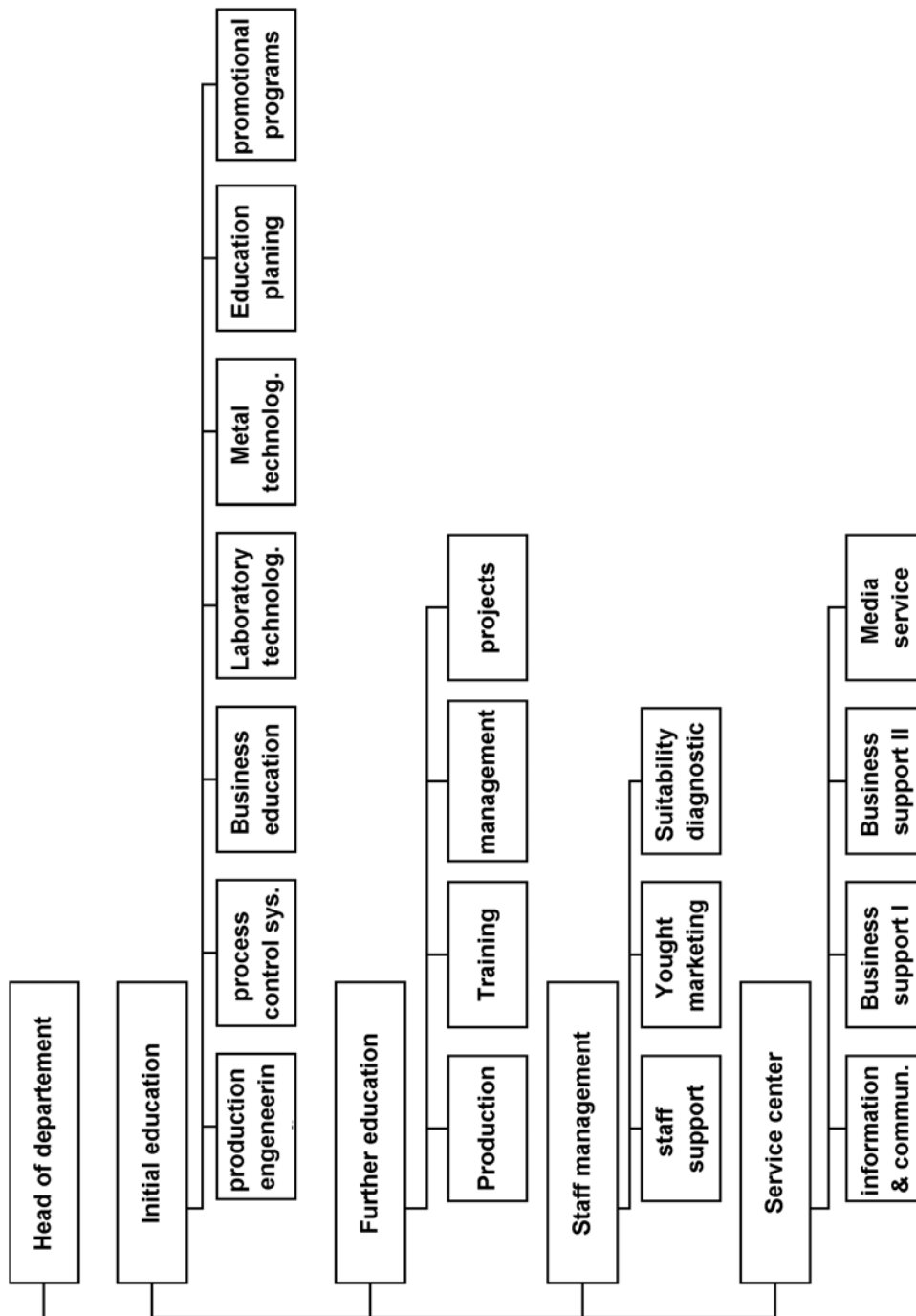

The Focus project meets with widely differing appraisals on the part of employees. In the interviews, those employees who had successfully mastered new tasks (e.g. project acquisition in the production sites) conveyed the impression that they had gained experience coping with this change that prepared them for the ongoing process of reorganisation at Company G.

The reorganisation of Company G opens up new fields of operations for the Initial and Continuing Training department, in that it now trains employees for the transformation of the organisation, as well as help and advice for the transition.

#### Cost-orientation

The training division was previously very much oriented towards the supply side and had an enormous catalogue of courses on just about every conceivable topic. Nowadays, every course is examined to see how strong the demand for it is and whether the effort and expense of designing a course is balanced by adequate demand on the part of paying customers. The other divisions at Company G must pay a certain amount for every employee they send to courses provided by the training division. The expenses for designing a course are overhead expenses. If the course is held only ten times, the overhead expense per seminar is, of course, much greater than if the course is held a hundred times. Cost analysis is now applied to every course, and the aim is to avoid frequently attended courses subsidizing other courses for which there is less demand.

### **3.2 Case 1: The use of work process knowledge and its integration in the documents of the company and in the qualification system**

#### **On-the-job learning (learning on the job as an organisational process)**

We want to discuss this case using the steam cracker as an example. This is not a single case in only one plant of the company but a concept which is distributed to a lot of other plants at the site of the company G.

The learning project at the steam cracker which should be introduced as a case of organisational learning involves the participative production of a plant manual. The plant was intensely confronted with the impact of the company's policy of promoting job cuts using early retirement offers – the loss of experience and know-how in the shift teams due to the loss of experienced workers. From this problem the learning company concept was developed. In order to counteract this loss of knowledge and experience, a project was launched in 1998 in collaboration with the training division that envisages the participative production of a plant manual for all process stages of the steam cracker. The plant manual became a kind of organisational memory for a major

proportion of the know-how essential for operating the steam cracker. It became the central basis of a teaching system and was linked to the pay system.

To understand the meaning of the participative production of the plant manual we have to have a look at the existing learning processes at the steam cracker.

### **Formal and informal learning processes**

Dividing learning at the steam cracker into two categories of formal and informal learning means first clarifying which learning measures fall in each of these categories. In Germany the formal learning is highly developed: Novices who want to start a career at the steam cracker (and who are supported by the plant management) without a occupation in the field of chemistry technology have to gain the vocational knowledge in chemical technology first. An education in the profession of the Chemikant (name of occupational profile) can be carried out during the work in the department of initial and further training. The requirements are the same as for the apprenticeship, but there are some differences in the execution.

### **Formal learning processes**

Selecting the workers who take part in the various courses offered by the training division is partly defined in organisational terms. For example, every new employee is sent on a so-called 'IW course'<sup>22</sup> to acquire the basic knowledge for working in a chemicals company. Other courses, also more or less specified, focus on the actual tasks performed and responsibilities assumed by the worker. For example, there is a Safety Officer who is regularly sent on safety training courses. When a worker, usually a trained operator or *Meister (master)*, is to be prepared as successor to a shift foreman, then he is predestined for certain courses such as *Meister* courses M1 to M4. In this courses he is trained for executive tasks. Topics are: handling of conflicts, working in groups, motivation etc. One of the day foreman whom we interviewed estimated that approx. 70% of participation at courses carried out by the training division are initiated by shift and day foremen, the remaining 30% are worker-initiated. These training schemes are included in the standard measures and are obviously not subjected to any further evaluation by the company. But the department of initial and further education is at least interested to estimate the satisfaction of the participant after their return to the company. They send them a questionnaire named "100 days after" and ask the participants whether they are satisfied with the course.

---

<sup>22</sup> IW: industrial worker.

Learning on the shifts can take place during the so-called ‘Five-Minute Safety Meetings’, for example. These meetings usually involve the shift foreman giving a short talk on a minor topic, e.g. how ladders are handled in a chemicals plant. These meetings used to be held once a week, but recently only once a month, presumably because the foremen were preoccupied with the large-scale shut-down (i.e. shutting down an entire plant).

Learning on the shift is also accomplished with training programs. For example, one shift worker we interviewed learned how to use pumps efficiently with a learning program written at Company G and installed on the PCs in the control center. These networked PCs can be used by all shift workers at any time. Other learning software can be downloaded over the Company G Intranet.

Besides the courses offered by the training division, there are also projects and workshops carried out by the steam cracker itself, in which participants are trained how to respond to industrial accidents and hazardous situations. Such on-site learning projects are relatively new and are aimed at preparing relatively young managers for the kind of situations with which they have gathered little or no experience to date. The aim of such measures is more to train the behavior than merely enhancing the knowledge of the participants.

One new measure at the steam cracker is the learning project called ‘Active Learning’. The project resulted from thinking about how to improve the training provided by senior staff (*Meister*) and how to improve learning for workers, especially self-directed learning. From these two initially separate strands of thought came the idea of integrating both – let *Meister* (trainers) and shift workers (trainees) work together on the ‘Active Learning’ project. In this way, one could ensure that both groups meant the same thing when talking about barriers to learning, learning methods, or the learning process, for example. Learners and masters jointly prepared so-called ‘learning cards’ detailing what the learner intends to learn in the period ahead. Learning progress was reviewed at further meetings of the ‘Active Learning’ project.

The development of new learning projects indicates that evaluations of existing forms of learning are conducted in a somewhat informal fashion. Quite obviously, learning in a ‘semi-natural’ form during work, supplemented by learning provided by training courses is not sufficient to compensate for the substantial loss of knowledge and experience resulting from early retirement. The development of new learning projects leads to a form of organisational learning that is best demonstrated with the example of participative production of the plant manual.

### **Learning at the steam cracker – Producing the operations manual by the work force**

In the chemical industry standard operating procedures are determined and documented in plant-specific operations manuals. These manuals are of much importance as they contain knowledge which is needed for running the plant, complying with safety regulations and for trouble-shooting. Usually, these manuals are produced by engineers who have an academic education and often have constructed the technical installations of the particular plant in question. Those engineers, however, usually do not have acquired much experience in running the plant day by day. To our knowledge, it was the first time that normal shift workers were charged with the production of an operations manual for a rather complex chemical plant.

Drafting and editing the operations manual for the steam cracker is organisationally controlled. At regular intervals, a team comprising one beginner, an experienced worker and a moderator meet in a container near the workplace and draft the description for a particular process stage. On average, every team has three up to four weeks time for writing their particular chapter. The manual explains how each process stage functions, how it is operated and which safety instructions must be complied with. The team is also responsible for producing exemplary questions which will be used for a technical examination that is going to be executed with the help of the handbook. The entire operations manual consists of 35 single folders (each containing one chapter).

The team starts its work with the collection of all relevant material (i.e. technical drawings, flow charts, list of devices) and information about a particular process stage. After doing so they start writing the text at a meeting. Whenever they have finished a section they pass it to the shifts requesting comments and corrections. By the next meeting, the team tries to clarify anything they do not know by talking to colleagues on the shift, the shift foremen, the day foremen or even the works management. It can be stated, that a very intensive discussion about the function of technical devices and the operation of the plant takes place during the work of the team.

The greatest learning effect arises in joint discussions within the manual team and in discussions with experienced workers on the shift. The shift foreman does not usually send the excellent workers to the container where the manual is produced, because there are only a few very experienced workers on the shift. However, direct participation of shift workers ensures that the manual is easy to understand.

“It’s easy to understand because you yourself are doing the writing and there aren’t many complicated words in it.” (Shift worker interview)

Employees who were not involved in producing the manual also confirm that the text is easy to comprehend.

The learning that occurred when writing the operations manual is without doubt the most intensive form of learning. The very act of writing compels the workers to think very carefully and precisely about what actually occurs in a particular process unit. Most workers understand rather quickly how a process unit is operated or what its most important function is when engaging in these kind of questions, whereas during continuous operation there is a lack of opportunities and motivation to think about the plant in any depth. Writing the operations manual provided such occasion.

Producing the operations manual tends to be welcomed more by younger workers. Some of the elder workers, especially some masters (*Meister*), seem to consider the work involved in producing the operations manual to be a waste of effort as they do not see the advantage of working hard for fixing a kind of knowledge what they already have acquired and what they expect to be acquired also by the younger workers in the course of time.

### **Using the operation manual**

The extraordinarily strong training effect in producing the operations manual might be seen rather as a singular event. In the beginning of our investigation it was not yet clear in which way the updating of the handbook would be performed in the future (today a team for updating the operations manual is vested). Within our empirical investigation we have therefore also focused on the normal and everyday use of the operations manual. Especially novices use this manual intensively who are extremely motivated due to the link between learning (respectively the success of learning) and the salary system (see next section). Because of the work-oriented content of the operations manual it is particularly used whenever work at a specific process unit has to be envisaged. As it is exactly described in the manual how a process unit is structured, and, first of all, how it has to be operated in particular situations, novices are able to prepare their work well with the help of the handbook.

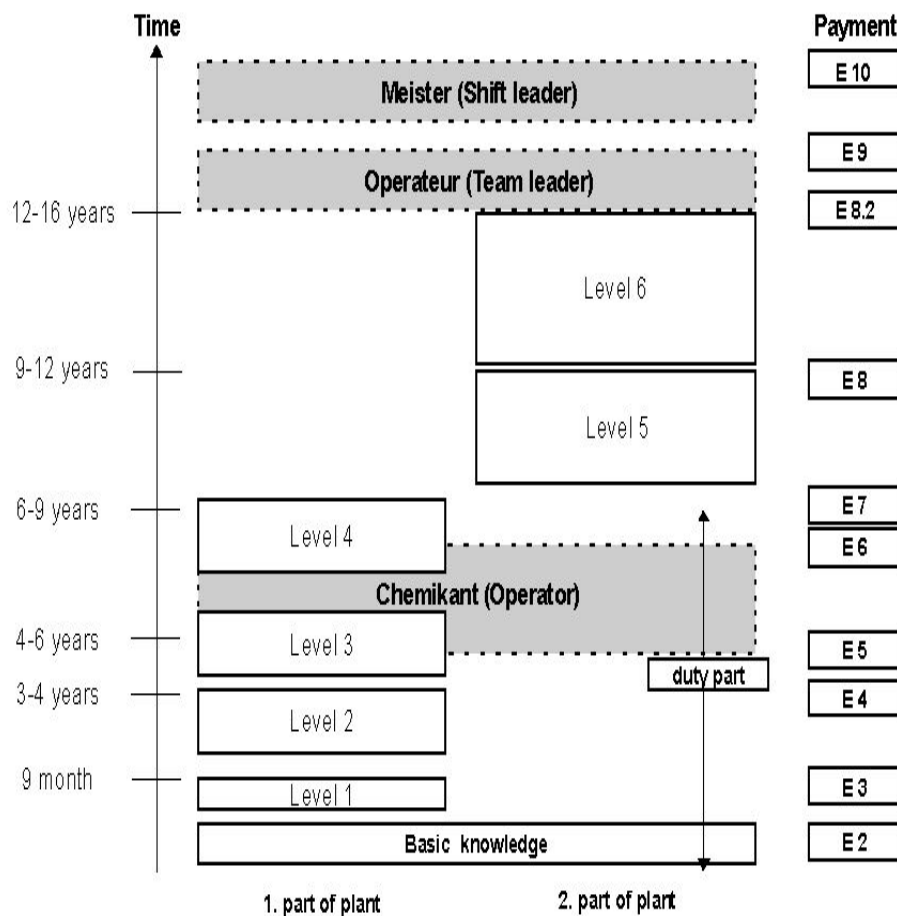

Figure 15a: The link between qualification levels and salary. E1, E2 etc are wage groups. Left scale: average time to reach this qualification level.

In case questions arise concerning the use of the manual, users often contact the authors responsible for the description of a particular process unit. If mistakes in the manual are detected and amendments seem to be necessary then a master who is registered as responsible person for the respective section cares for the up-to-dateness of the manual.

### The link with the wage system

Novices with vocations from outside the field of chemistry receive rather few money when being engaged by the company. The difference between this primary wage group and those of a skilled chemical worker is four to five wage groups. Since the operations manual was introduced there is the opportunity that novices raise one wage group in salary each time they successfully pass an examination (a kind of technical discussion). They are able to prepare this technical discussion very well with the operations manual as it contains exemplary questions (similar to the examination questions) for each qualification level. In former times the rise in salary was dependent on a judgement by

shift- and day masters. Today workers may register to the technical discussion at the higher management level independently from the master.

<b>Basic knowledge</b>  “Approach to the plant”	→ <b>Knowledge:</b> give information about, name → <b>Recognition:</b> to refer to, define → <b>Ability:</b> describe, assign
<b>Basic program</b>  <b>“Operate inside and with the plant/facilities ”</b>	→ <b>Knowledge:</b> Overview about some parts of the plant (steps of the process) → <b>Recognition:</b> Early recognition of causes (assumption) of irregularities in the process → <b>Ability:</b> Monitoring, “Approach to regulation and control”
<b>Intermediate program</b>  “Operate with a complex plant“	→ <b>Knowledge:</b> Describing effects of regulation and controlling of the plant, the processes and the open- and closed-loop control → <b>Recognition:</b> Distinguish between reaction and consequence → <b>Ability:</b> correct description of irregularities, intervention and regulation
<b>Extended program</b>  “Independent forms of practical planning and action”	→ <b>Knowledge:</b> Explaining complex connections inside the plant facilities → <b>Recognition:</b> Explaining preventative measures to avoid disturbance → <b>Ability:</b> Eliminate disturbances, measures of starting and shutting down the plant

*Table 1: Taxonomy of training goals of the different qualification levels (Quotation from an operational document).*

Each wage group is connected to a qualification level (see figure 15a) which itself is related to a taxonomy of training goals (see table1). The beginner uses the operations manual in order to get a general idea of the plant. He or she then reads the part of the text that gives an overview of the functioning of a particular equipment and answers questions from the operations manual which are related to basic knowledge.

### **Interpretation as organisational learning**

Producing and updating the operations manual, as well as integrating it into the process of skilling workers, must be interpreted as an organisational learning process. Previously, the process of skilling shift workers primarily depended on the initiative of shift foremen and experienced shift workers. The organisational process of preparing and updating the operations manual implies that an important part of the knowledge of employees is added to the organisation’s ‘memory’. The skilling system, linked as it is

to the payments system, provides organisational processes for distributing the knowledge stored in the various documents comprising the operations manual.

The process of writing and using the plant manual matches our criteria 1, 2 and 4, to some extent criterion 3, having its main emphasis on criterion 4 (knowledge creation and knowledge management):

- The knowledge about the plant which is necessary for direct operation is documented, generalised and assessed. This was to a certain extent formerly done only by engineers.
- The knowledge about the plant which is not immediately useful for direct operation but might be necessary in case of emergencies is also activated by the plant manual: On one hand, during the writing, when systematically all parts of the plant have to be considered; on the other hand, during the systematic examination which is organised on the base of the plant manual. Up to then workers did not have the opportunity for systematic reflection.
- By the participation of the shift workers in preparing the plant manual, they will be able to use all of the information sources of the company. In former times there was hardly an opportunity for the workers to come in contact with the department of documentation. During the preparation of the plant manual, the workers always have to collect all necessary documents.
- By the participation of the shift workers in preparing the plant manual, they will be able to use all of the information sources of the company. In former times there was hardly an opportunity for the workers to come in contact with the department of documentation. During the preparation of the plant manual, the workers will always have to collect all necessary documents.
- By the correction of the texts written by the teams, the workers from a certain shift will be stimulated to discuss the concepts of controlling the plant, running the plant and the connectivity of the functions. In former times there was no occasion for such kind of discussions. The concepts of controlling the plant, running the plant and the connectivity of the functions were explained to the novices by the master or experienced workers. The novices had no other possibility but only to accept these explanations. By fixing the explanation as text of the operations manual, it can be critically re-examined. In former times it was very hard for workers to make this kind of consideration.
- Every team that has prepared a part of the plant manual was composed of workers from all of the shifts. During the discussions about the correct version of a text, the workers became aware that every shift has its own style to run the plant. In former times there was little communication among the shifts, so the workers from one shift considered their way to run the plant as the only possible one.

The mental models of the shift workers and the master about their plant and the way to operate the plant were changed through the process of preparing and using the operations manual. The concepts about the role of workers in the work organisation have been changed, too. For example, the female moderator of the teams reported in an

interview, that at the beginning of the project angry shift masters complained about shift workers who were sent by themselves to the teams. The main point of the complaint was the awakened self-consciousness of workers who made themselves independent from the information flow controlled by the master. From then on workers regularly ask questions about technology and functions in the plant and they did not immediately trust the information given to them by masters and foremen.

If we call in memory that organisational learning in the sense of double-loop and deuterio learning implies a structure created by the organisation through which individual learning is permanently stimulated, documented and evaluated, then a conclusion as follows has to be drawn:

In former times individual learning of novices in the steam cracker happened in an informal way and to some extent coincidentally. If novices were motivated to learn then masters answered their questions and stimulated them to continue learning if time and opportunities were appropriate. The transformation of this informal training process into a structured introduction to the knowledge necessary for running the steam cracker must be regarded a process of organisational learning. Of particular importance is in this case the link to the wage system through an examination (a “technical discussion” in the terminology of the company). Due to this link it became necessary to set up a taxonomy of training goals and to provide learners with a structure of contents within the manual which were oriented to the needs of the learners and not exclusively to the functionality of the technical installations. By the examination through the technical discussion it shall be ensured that learners have understood the contents of the manual. For this reason there are not any marks or grades as a result of the examination. The learner has successfully passed the examination if he or she could correctly report at least 80% of possible answers. Who has surmounted this hurdle will be rated in the next higher wage group.

For the preparation on the examination by means of the exemplary questions from the operator manual it must be made clear what is expected from the examinee. For this reason a discussion about the contents to be studied takes place at the steam cracker. In former times there were no need for such a discussion. Every master and every shift regulated the skilled worker advancement after their own criterion. The present examination system has moved this situation to a rather objective basis. The participation of all shift employees has contributed to this particularly. It was made sure that the correct contents are being examined. The evaluation of these procedure in the sense of an organisational inquiry after Argyris and Schön is dependent on how thoroughly the operations manual is revised by the work force. The operations manual is not only used for the examination, but as well for preparing real work tasks within the

plant. It does not have to be expected, that the contents of the operation manuals and the contents which are needed for work, drift very much apart from each other.

### **The culture of the steam cracker**

In the eyes of one of the works managers we interviewed, no major change has occurred in the way members of management treat the workers. Thanks to improved skilling of workers, however, he does expect certain impacts leading to greater independence of workers and more individual responsibility, although more in the sense that workers extricate themselves from management control than that the works managers change their own behaviour. Some of the works managers are described by some workers as unapproachable persons. Traditionally, leading managers in the German chemical industry were doctors of chemistry who valued a strict hierarchy and made sure that this hierarchy is respected by other persons.

Nevertheless, it must be noticed that there are changes in the corporate culture. In former times a project like the participative production of the operations manual was unfeasible, and the reason for this seemed to be rooted in the thinking of the managers. In their opinions, workers did not have the ability to write something like a plant manual. Such a task, they thought, could only be done by a graduates. Nowadays, workers write the operations manual by themselves and they do this with great success.

Quite obviously, the exchange of the leading works manager did not have much impact on changing the behaviour of the management level below. In workshops, some workers expressed criticism of the foremen, who failed to pass on much of their dissatisfaction to the management. These dissatisfied workers were obviously afraid of approaching the leading works manager directly. This is despite the fact that, at meetings in the control centre attended by all the workers, the leading works manager actually requested the work force to express their comments and critical remarks.

In the eyes of most of the work force, it is not a common practice that the workers consult the management directly, despite the fact that the work manager asked for comments and remarks. In former times the relationship between works management and the employees was regarded as not satisfactory, at least by a part of the work force. This is clearly evident in the cautious comments by various workers who said that the demands imposed by the works management were increasingly intensified with little consideration for human interests. This also led to an employee survey, which was evaluated according to the various divisions within company G, indicating a negative atmosphere in this particular plant.

The Training Officer in that plant considers it essential to introduce measures for building confidence between the works management and the shift workers. For example, he proposes that each shift should introduce ‘consultation hours’ in which the works management can get in direct contact with the shift workers, and not just communicate with them through the shift foremen. The Training Officer would also prefer to implement an established set of measures, between works management and workers, through which discrepancies between self-perception and perception by others could be explored.

### **Employee survey**

In the employee survey, workers are given the opportunity to assess the leadership qualities of their works managers. The works managers then receive feedback on the results for their particular plants or departments. However, little use is made of this opportunity to identify potential for change. One interviewee noted, that the employee survey enables criticism to be vented, but provides little opportunity for initiating change. When a senior member of staff is assessed poorly, he can always justify his doing by saying that he is not the one who has to change or that he is not responsible for initiating change, but that this lies in the responsibility of his senior manager. The many levels of hierarchy foster a situation in which problems are passed on to others instead of being tackled.

In a particular works, the workers and also the foremen usually only know their immediate superiors. Only in very rare cases do they get to know other managers, such as departmental or divisional managers:

“Well, we actually see little of any heads of department or heads of division. When we do see them, then something serious is going to change in some way or other, or something serious has happened. Then you see them, otherwise you don’t see them.”(Shift worker interview)

### **Knowledge management at the steam cracker**

An important field of knowledge that has to be conveyed to as many workers as possible in a single enterprise concerns the causes for disruptions in production. In the steam cracker a large proportion of the knowledge available to the organisation about such disruptions and their causes was lost because experienced workers retired early. Early retirement by experienced workers has adverse impacts on the dissemination of knowledge during the shift. Because the remaining experienced workers are mostly deployed on management tasks, those who are remaining on the shift are often the ones who cannot teach much to the novices.

The experience of losing this knowledge was a factor that stimulated the participative production of the operations manual, which can be interpreted as corporate knowledge management. Reports on the most important accidents are integrated into the manual. The most important knowledge creation was the fixing of informal knowledge in documents of the organisation. Before this process of knowledge creation started, the organisation has not learned what the workers know, because the knowledge of the workers was not fixed in a form accessible for organisational measurements. Now, this part of workers' knowledge which is fixed in organisational documents is accessible for organisational measurements like the personal development system or the qualification system of the company.

However, there are still some barriers visible towards knowledge acquisition and knowledge management. For example, one interviewee who completed training as a chemicals operator outside company G is highly interested in regulation concepts as part of process control. In his opinion, the elder workers in company G have acquired knowledge about regulation concepts which enable them to act efficiently, but they are not able to communicate the background facts that explain the success of their actions. Their knowledge about chemical reactions, technical installations and the process control system was acquired in their daily work, which leaves little scope for more in-depth exploration of underlying causes and effects. Trained chemicals operators, on the other hand, had time during their training to familiarise themselves with process control principles and the functional principles in the technical field. The explanations given by elder shift workers are often based on experiential values that they are unable to explain any further and for this reason are dissatisfying for the younger, trained chemicals operators.

The informal exchange of knowledge is fostered by various activities, for example sports events. The works management supports indoor bowling and football. Within company G there are tournaments involving various works teams.

### **Learning from the environment**

Operating a plant as complex as the steam cracker permanently confronts the work force with major or minor problems, the solutions to which accumulate in the course of time as experience-based knowledge of the steam cracker employees. For this reason, every works manager, every works engineer and indeed every employee is interested in how the typical problems faced in a steam cracker are solved by work forces elsewhere. Within company G experience is exchanged between specialists with steam cracker experience – an exchange that originated in the German site. This is where the first two company G steam crackers were built and a body of know-how amassed that was also

used in building a steam cracker of company G in Belgium, for example. In 2001, during the large-scale shut-down in the German site, workers from the steam cracker in Belgium came to the German site to learn how the total shut-down can be carried out efficiently and which cleaning methods have proved to be particularly effective.

The involvement of experienced workers from the German site when building other steam crackers (e.g. the world's largest steam cracker is being built in the USA at Port Arthur in Texas), or when carrying out total shut-downs, enables these workers to gather further experience that greatly benefits the German site as well, because a steam cracker during normal operations provides much fewer opportunities for training than when constructing, starting or shutting down a steam cracker.

The workers who spent some time abroad on one of these projects tend to advance their careers, with some of them joining the shift management team, for example. In addition, because company G has at least six steam crackers, some opportunities exist for the work force to gain experience.

Collaboration between company G and other steam cracker operators is confined to safety issues only. For example, when a plant discovers that a certain welding seems to cause safety problems, then problems of this kind are communicated. Problems of a general nature and ways of solving them are not discussed with competitors, however.

In the German site, learning from the respective other steam cracker was fostered by merging the two control rooms. For the day shift foremen and higher levels in the hierarchy, both crackers are part of the same organisational entity. Workers may be swapped between the two crackers, but this is not for systematic reasons.

Almost all steam crackers in the world are subjected to benchmarking. In the so-called 'Solomon Study', the data for various parameters of steam cracker operation are listed:

“And according to which criterion are the crackers compared?” “How many dollars you can squeeze out of it. The basic criterion, such as use, operation, personnel, production stoppages, availability, products, product range, what you get out of it, what you do with it, how much this is, what the ratio is between different product volumes, what the energy prices are, what kind of energy is used, and if yes, at what prices. So 2 kg – the report – is what comes out of it.” (manager interview)

This study ranks the steam crackers and if one is given a bad ranking the works manager has to justify this. However, as the study mainly focuses on details that are financially interesting, it is not easy to explain good or bad performance on the scale. Whenever a steam cracker is designed, many boundary conditions are set that cannot be changed during actual operation. In particular, the size of a steam cracker is very important for efficient use. Older, smaller plants in Europe are competing with newer,

bigger plants in Asia and America. It is not possible, on the basis of the Solomon Report, to compare different ways that the plants are operated, or other factors relating to work organisation at the steam cracker. From the economic perspective, only the number of employees per tonne of ethylene or propylene produced is interesting.

It seems that the steam cracker in the German site does not learn too much from other steam crackers, but they transfer a lot of knowledge to other steam crackers. These organisations are now constructing their own knowledge. The question remains open how the German organisation could benefit from the experience being accumulated by the other steam crackers. It seems that the German site has not recognised yet that they can learn from others. At least, they have not taken up any measures.

### **Conclusions**

Altogether, it can be stated for company G that organisational routines and processes (e.g. standardised work procedures) are evaluated (the first criterion). The company provides help (Treffpunkt-i-procedures) for the check and the redefinition of the organisational procedures of the plant. This support and particularly the participative production of the operations manual has led to a real change and redefinition of organisational routines and procedures. However, it was not a result of an organisational inquiry to launch such a project, but the individual idea and decision of the leading works manager.

The second criterion (formal and informal learning processes are being evaluated and improved), is also fulfilled. First, a number of new learning processes have been inspired in the case described above. Furthermore, the steam cracker experiments with new forms of learning to find out the adequate one. This is the explicit goal of the project “active learning” where the trainers of the steam cracker learn how to conceptualise and to perform work-related teaching methods, and the trainees are getting acquainted with different types of learning methods. A remarkable project is the participative production of the operations manual. This project fulfils the criterion the best.

The third criterion (transformations are occurring in the culture) is fulfilled only to a certain extent. On one hand the traditional hierarchy still exists and leads to problems of communication and co-operation between management and work force. On the other hand a more implicit change in culture can be recognised: There is an awakened self-consciousness and there are improved competencies of workers

The fourth criterion (knowledge is being created within the organisation, at different levels and is being shared within the organisation) is strongly fulfilled. The knowledge

for the running of the steam cracker is created by the workers. Through the qualifications system based on the participative production of the operations manual, this knowledge is shared within the organisation.

The fifth criterion (learning from the environment) is fulfilled only to a minor extent, as some possibilities for learning from the environment are used by the steam cracker, however not in the case of the handbook project. Also the above mentioned actions (like exchange of personnel) cannot be regarded as measure of organisational learning as there is no intentionally created and systematically controlled relationship to ‘learning from the environment’.

The development and use of knowledge within a company has always been a cause for dispute in regards to its usefulness for the individual or the company respectively. The concept of the learning organisation interprets this dispute anew. Our findings lead to preliminary conclusions as follows:

- The case described meets the criteria 1, 2 and 4 which were suggested in the theoretical framework of the OrgLearn project as important for organisational learning:
- In the case described the main emphasis lies in the provision of an organisational structure for knowledge creation and knowledge sharing. The knowledge to be created and shared is what we call work process knowledge: knowledge about the whole labour process within the factory including reflection on practical and theoretical knowledge that might be useful for work (Boreham et al 2002).
- There is an increase of self-organised learning and a reduction of personally controlling and determining learning processes by masters and foremen. Learning processes are on one hand more independent from personal control (by middle managers), on the other hand more objectified through manuals, procedures and regulations, however not eliminating partial self-organisation. The content of learning is oriented towards the running of the plant, combined to some extent with career opportunities. The content of learning is not oriented towards job descriptions and the range of vocational competencies which are defined by the German “Beruf” (cf. Fischer 1998).
- Processes of organisational learning were stimulated by a remarkable reduction of personnel and a loss of experienced workers. Organisational learning can be regarded as an attempt to compensate the loss of know-how. In particular, measures of organisational learning are taken up in advance to protect the company from a loss of know-how that might happen in the future.
- Knowledge which formerly belonged to the individual worker or a group of individuals is objectified in two ways: It is objectified through a process of generalising individual knowledge and it is objectified through artefacts – means by which knowledge can be stored in a “memory” of the organisation. It is not yet clear to what extent organisational learning may support an outsourcing-and-insourcing policy (Mariani 2002) and to what extent the individual worker benefits from processes of organisational learning he is involved in, especially if he is leaving the

company.

### **3.3 Case 2: Change of the culture of the organisation sulphite factory**

Change of culture is a global goal of company G. But how can this goal be accomplished? We want to present a case of cultural change induced by a manager, who is confronted with an old culture, in his new position as a plant manager in the sulphite factory. First, we present the findings of elements which match our criteria.

#### **Continuous improvement in the sulphite factory**

The latest major suggestion for improvement in the sulphite factory involved redesigning a packaging machine. The savings achieved were Euro 45,000. The suggestion was submitted by a shift worker and a maintenance technician. The suggestions scheme runs largely on 'autopilot', i.e. stimulation by the works management and the shift managers beyond the group advertising is needed to a minimal extent only.

On the ground floor of the sulphite factory, there is a board on which everyone can post a suggestion for improvement. The suggestions are examined by the plant engineering foremen or the plant operators, depending on whose scope of responsibility the suggestion falls under. Good suggestions are recommended for 'Felix Findig', the Company G suggestions scheme. In the year 2000, approximately  $\frac{3}{4}$  of the submitted suggestions for improvement were actually implemented. 16% of the savings achieved are paid out as a bonus. Managerial staff from the foremen upwards are expected to make suggestions for improvement without receiving bonuses.

#### **Organizational changes**

Employees can barely remember the changes made so far in the sulphite factory's division. From their viewpoint, the effects are confined to the abbreviation for the department. They know that some production sites were added to other divisions, but cannot remember the details. The reorganisation of divisions has led to a separation of the inorganic and petrochemical sites.

In the sulphite factory, dispatch was integrated as part of the factory.

Participation of the shifts in the planning of rebuilding work and changes to the production plant is in need of improvement. Workers have the feeling that they are often presented with *fait accompli* and that they have no opportunity to intervene in any way in decision-making processes. That said, they are the ones who work on the production plant every day and that have to live with inadequacies of all kinds. Until now, the

workforce is merely informed after the event, by means of an information folder, about modifications that have been made to the plant.

## **Formal and informal learning processes**

### **Training of and by foremen**

One of the important aspects of the formal learning during further training is the education to become an executive below the academic level. In Germany the segment of executives within the labourers is traditionally taken by master craftsmen (“Meister”) and technicians. With the changes in the organisation of production there have been, in particular in the automobile industry, many alterations in the function of the master craftsman (“Meister”) in the last years. Traditionally he is more seen as a “miniature boss” that assigns tasks to the workers assigned to him and controls the realization of their work. However, this role is changing in the chemical industry and with centralized seminars and training units (M1 to M4) Company G tries to prepare their master craftsmen for the change.

Those attending the courses for *Meister* (M1 – M4) are trained for leadership roles. During the course, interview training for instance, is provided in which two participants have to share roles and act out an interview. The topic could be health and safety at work. The interview is assessed by the course leader or tutor. Another variation is that the course leader plays the role of works manager and the course participants have to respond to him in an interview situation. Some of the foremen we interviewed have a low opinion of these courses because they do not believe that the behaviour of shift workers can be modified with interviews:

“I think it is good to listen to [the interview training]. But 90% of it you can’t use. Because like I said there are people there [shift workers, P.R.], who are just stubborn and you can talk to them as much as you like and sooner or later you give up trying.” (UGO 374/438)

A central motive of the learning company, the evaluation of central learning measures with respect to their local effect, seems to be unsuccessful in this case. Even though the interviewed master craftsman learned communication techniques and leadership during the seminars, he did not approve of the underlying concept of these techniques, to regard the worker as the main and developing resource of the company.

Training a new worker in the sulphite factory begins with safety training that covers the key risks in the sulphite factory. The workers must know what to do when an SO<sub>2</sub> alarm sounds, for example, or that he has to change his clothes if he has been contaminated with alkali or other substances. These instructions are given by the day shift foreman or the works manager himself. When the worker is then assigned to a particular shift he

usually has to work on the filling side and receives further instructions and demonstrations from the shift foreman. A sponsor from the shift is assigned to whom the new worker can always turn with any questions he may have.

After 8 to 10 weeks, the novice joins the control centre and someone (mainly the shift foreman or the sponsor) explains the PI flow diagrams<sup>23</sup> to him and how the control centre operates. In the course of time, if the worker has understood everything well, he is trained as a plant operator in the control centre. However, there are cases in which new workers fail to reach the standards required by the control centre and return to the filling plant again. There are also workers from the time when many of the activities in the sulphite factory were still done manually and who were employed in those days as manual workers. Some of them are unable to meet the learning requirements associated with automation. These workers are used almost entirely for cleaning work.

The ‘Five-Minute Safety Meetings’ are held on the shift, mainly during the night shift. The shift manager or the safety officer takes the current sheet from the Safety Calendar and talks it through with the shift workers. The result (e.g. answers to questions in the calendar) are entered in the calendar. Once a month, the safety officer for the shift provides a training session, e.g. on checking the fork-lift before starting work.

The training measures are monitored by the shift foreman checking the way that shift workers perform their work. The shift foreman checks how work is done by the shift workers during his 20 to 30 rounds per 12-hour shift.

### **New learning methods**

A basic principle is that every worker should have access to the Intranet. For example, he can study the entire range of courses offered by the training division or find topics for the Safety Meetings. However, to access the PCs in the sulphite factory, workers have to go to the foreman’s office. A worker has to express to the foreman what he wants. The form then allows access to the Intranet.

### **The role of managers as learners**

A new role of managers in respect of their own role as learners can be seen from the following comments made by a plant manager:

“That’s exactly how it is – I only know the basics about the PCS<sup>24</sup>. I ... and now we’re back to the subject of worker assessment, but that’s part of it, I’ll

---

<sup>23</sup> PI flow diagram: flow diagram of pipes and instruments. The diagrammatic portrayal of the process engineering system and its components, supplemented by many other details such as type of material, class of piping, etc

<sup>24</sup> PCS: process control system

also sit down and get the shift manager or a plant operator or anyone who knows the PCS to explain to me how it works and I'll learn from him (..) I'll go to the sieving machine and learn from the packer about the problems he has with the siever. And in fact that's also what I expect from others, (...) from the shift manager and the foreman, that he finds out from the packing machine operator what problems he has and that he tries to learn from the operator, because he's standing there 12 hours a day and nobody knows the machine better than he does."

This is a different view to the workers if compared with the opinion from the masters. The question is in which way can the culture within the sulphite factory develop further?

### **The culture of the sulphite factory**

#### **The image that workers have of the company**

The image that workers have of Company G is examined by discussing occurrences such as accidents involving emissions. The meetings discuss and explain the causes for the accident and what exactly happened. By dealing with accidents in this way, every worker is made aware of how large the discrepancy is between the image of Company G as an eco-friendly chemicals company as the ideal state and the real state of affairs, and everyone is reminded of their commitment to work on reducing this discrepancy.

The attitude of workers to company policy is noticed, for example, during the discussions with the works manager. When the occasion, e.g. the 'Fit for the Future' project, occurs, workers meet with foremen and the works managers and are informed about particular projects, or about action already taken, such as the sales of Group companies. At such events, displeasure among the workforce about corporate policy is sometimes voiced.

#### **Evaluation of corporate principles**

Company G, like all major chemicals corporations in Germany, has made enormous efforts in recent decades to improve its image among the population at large. In the course of the environmental debate, the chemicals industry has implemented many measures to reduce pollution from chemicals production, and initiatives have been launched to enhance environmental awareness among the workforce. In more recent years, especially, Company G has become increasingly open to environmental issues.

The sulphite factory is a good example that by combining several chemical processes a drastic reduction or even a complete avoidance of pollution can be achieved.

From the viewpoint of plant operators, it was necessary that Company G change its behaviour vis-à-vis the outside world if they want to gain credibility and pave the way

for an understanding of their business and operational concerns. The discussion about Company G's image among the populations was not only conducted within the sulfite factory but also at the other plants:

Communication about the behavioural principles of Company G is welcomed by one works manager, because precisely by putting these principles down in writing a basis for assessment is created that is beyond individual discretion. An example is the codification of the principle whereby German and non-German workers must be treated equally. The same is true of the stipulation that statutory regulations must be complied with even when such compliance has adverse impacts for Company G. Every Company G employee received a copy of these principles of conduct in his private mail. To ensure that the contents were read, taken seriously and properly understood by every employee, a series of meetings on the rules of conduct were held in the company:

Implementing new rules of conduct in respect to the environment plays an immensely important role in the chemicals industry. In order to sharpen environmental awareness and refresh people's knowledge of environmental regulations, a number of different measures are taken.

From the workers' viewpoint, behavioural changes on the part of Company G management are closely associated with worker participation in in-company discussions about operational disruptions and changes to production plant. In the past, there were no joint discussions about the cause of disruptions.

As far as corporate communication is concerned, it is quite common practice to address specialized questions to the relevant specialist within Company G by phoning the latter and asking for information. Finding the right specialist is made easier by the way the telephone book is organized and by a new database on the Intranet. As long as the problem is assigned to the right field, expert help can be found within Company G.

### **Knowledge dissemination in the sulphite factory**

Knowledge is informally and regularly exchanged in the sulphite factory between the 'tradesmen', when the safety certificates are handed over. This opportunity is used to 'chat' a little about this and that.

Although there is a meeting every year of all the foremen in the Inorganic division, which the sulphite factory is part of, this event does not generate any persistent knowledge about what goes on in other works within the division. The interviewees were little informed about other works, be they geographical neighbours or enterprises within the same organisational entity.

Intranet and email resulted in the dissemination of knowledge, e.g. about the courses offered by the training division, without being filtered anywhere along the line. Provided they have access to and can use a PC, workers can acquire knowledge freely and independently of their immediate superiors at work.

### **Learning from the environment**

There is no benchmarking with other plants in the production of sulphites. However, there are some studies on the possible processes used by competitors, especially when they offer high-quality products at a lower price.

In the sulphite factory there are many external experts and analysts. Because sulphites are used in the food industry, for example, external experts are sent by food producers and check production conditions in the sulphite factory. Different criteria are applied, depending on the cultural origins of the experts concerned. For example, there are Israeli rabbis who examine production to ensure that the product is produced according to kosher rules. The external experts generally check whether processes in the sulphite factory are performed in accordance with the quality manual. The manual stipulates, for example, what must happen if there is deviation from the quality standard, who must keep a log of quality deviations, or what must be done with products that fail to meet certain quality criteria.

Parallel to the increase in external audits there are also internal audits that go beyond quality management and which audit the entire production management. Within Company G, enterprises are compared on the basis of key figures that indicate, for example, how many accidents have occurred at a production site, how many customer complaints were received, what the absentee rate is and how many suggestions for improvement were made.

### **Conclusions**

During the shifts, the functions of a problem-solving-group are exercised. However, the master craftsmen dominate and the systematic inclusion of employees seems to be in need of improvement. The search for improvement of the production is done intensively. The inclusion of the employees of the shifts for the improvement of the production, however, seems to be in need of positive changes. The QM-system is followed and developed further; the learning processes of the work force are formally guided by the QM-system. From the difference between the defined requirements of the work place and the actual qualifications of the person who works in this work place the need for qualification is derived. However, so far one can not yet reveal if this system has undergone an organisational analysis (after Argyris and Schön).

The market position of the company seems to be an only somewhat developed topic among the shift workers.

The investigation of learning processes is done according to hierarchy, more in a sense of a check than an evaluation. The exchange of knowledge and experience beyond the boundaries of the company does not happen on the level of the shift workers and is only very slightly developed on the executive level. The development of a new learning role is well pronounced on the executive level but on the master craft level there seems to be an insistence on old learning patterns.

The culture of the company has developed strongly with the ongoing environment debate and opened to the societal surroundings. The personnel however, seems only somewhat able to critically reflect the principles of the company and apply them to the world within the company. Processes to change the organisational structure do not seem to be initiated by the personnel, but the company manager has realized this problem and tries to change the situation. There is, for instance, the willingness to enlarge the learning possibilities by technical systems and procedures and there is a procedure for the workers to participate in the continuous improvement process.

An organisational creation of knowledge on the level of the shift workers and shift-master, for example, by the creation of a plant manual at the steam cracker, seems not to exist in the sulphite factory. The plant manual was written by a plant manager; however, it was checked by the day-shift-masters. For outsiders, the plant manuals appear to be relatively similar, since the plant manual of the sulphite company also contains very detailed instructions for operation.

The generation of informal knowledge happens, for instance, in exchange with the craftsmen to whom a close contact exists but this is not organisationally stimulated.

The intranet is used, for example, to concentrate material for schooling or to get information about the status of the whole enterprise.

A comparison with other companies does not seem to exist. The knowledge of the workers about neighboring or other factories at the location is very poor. However, the external evaluations take place regularly and are taken seriously as learning opportunities. Learning from others shows in this case the interesting variant of others coming into the plant and judging it.

Through the marketing, information about the markets for which the company produces are collected. However, the plant does not react autonomously to these markets, but it is embedded in selling and marketing in the whole enterprise.

### **3.4 Case 3: Orientation to processes as a reference point for the initial training in company G.**

#### **Orientation to work process knowledge as an external reference point and Orientation to education process as a internal reference point for organisational development and organisational measures**

One of the very important tasks of the department of initial and further education (see p.72) in the last years was to develop a new conception of itself. In the past it was adequate to offer a big catalogue with a long list of seminars. Little attention was paid to whether the seminars were really useful for the participants. Whether the seminar participants really learned something that was useful for their work wasn't systematically checked by the education department. In addition, there was little attention to the profitability of the seminars. Little thought was put into the relationship between the costs which arise from the seminars and the frequency of the seminars. The benefit of the seminars to both sides (to the participants and to the department of education) wasn't evaluated very well.

This situation was changed by a project called "Focus" some years ago and a quality system was established, which should ensure that the quality of the product of the education department is improved and meets the needs of the costumers. The department endeavours to translate quality management ideas into practice as far as possible. Regular checks are carried out to determine whether customers, i.e. those taking part in training schemes, consider the material conveyed in courses to be useful in their work – not only at the end of the course, but also 100 days later. In 2000, the company also started inviting some customers of the training division to act as auditors for its own quality management system.

Change management within the training division is described in the quality manual in the form of various projects. There are A, B, and C projects, for example. A 'C' project could be involved in developing the range of courses, for example. One 'A' project is the Focus project, for example, in which the structure and organisation of the division is called fundamentally into question. An 'A' project must have a control group with a predefined composition. A 'C' project has a much simpler structure by comparison. These criterion are defined in the quality manual and checked during the annual quality audit. The control group for an 'A' project must include management representatives from the level above the division concerned, as well as customers of that division. There must be a project manager who acts as a transition manager, and documentation of project execution must meet certain requirements. In the case of a 'C' project, there is only an agreement on objectives between the project manager and his group leader.

A further measurement in the frame of the quality management system is the test using key figures to determine the quality of training received by trainees and apprentices. One is the drop-out rate per recruitment year or course, or the percentage who discontinue their training for personal reasons. The aim is to reduce this figure to under 5%, if possible. To achieve this aim, the company introduced a new task in the position of 'support trainer' (Betreuungs-Ausbilder). In former times, the support trainer was a kind of passive contact person. Whenever an apprentice or a trainee has troubles with trainers, teachers, other trainees or in his private life, he or she could appeal to the trainer. The new role of support trainer is a more active one, which means that the trainer accompanies a cohort of apprentices during their vocational training and that he does a lot of the education. In the past, most of the trainers were specialised only on parts of the education of the trainees.

In addition, all important information about the trainee (grades achieved, conspicuous aspects) are stored in a database and used as references in the so-called '*Mittelgespräch*', for example. The *Mittelgespräch*, or 'Middle interview', refers to a midterm meeting with trainees whose performance is below par. During the meeting, an assessment is provided of how successful the trainee has been so far and what his or her prospects are. Of the cohort that finished its training during our study, a midterm meeting was held with 32 of approx. 200 trainees. The result was positive in 22 cases, i.e. these trainees went on to complete their training successfully. 10 trainees did not take the meeting seriously and failed their training.

Each year there is also a management review, at which instruments such as the midterm meeting are assessed for their effectiveness. The midterm meeting was evaluated as successful.

### **The trainer in the quality system**

A major proportion of the vocational training at Company G takes place in special training workshops, technical education centres and laboratories. In recent years, on-the-job training modules in the production plants have been increasingly added to the normal system of off-the-job training. Because the trainers themselves have lost contact to the operational side of work due to the isolation of the training division from the operational enterprises, efforts have been made in recent years to re-establish such contact, for example through visits by trainers to the production sites. That means, that trainers go to a plant for four to six weeks and work there. Their task is to study the actual situation in the work processes, to investigate what kind of learning possibilities for trainees are available in the plant and to make connections.

The training division aims to have trainers visit production sites every 4 years when possible, but in their own estimation, they are still far from reaching this goal. For each trainer, there is a history of qualification, from which one can see what further training schemes he or she has attended. There are also recommendations for the frequency at which trainers should participate in certain further training schemes.

### **The relationship between vocational training systems and the organisation of training**

The redefinition of occupational profiles also leads to organisational changes in the training division. In the case of chemical laboratory workers, for example, the trainer teams for the various laboratories in which training for chemical laboratory workers is provided have been reorganized. The same is happening with the technical education centres.

The intensive division of labour within Company G, as in other German industries, is reflected in the occupational structure (some would go so far as to maintain that the occupational structure has shaped the organisational structure of companies). The occupations of industrial mechanic (specialized in plant engineering), power electronics engineer (specialized in plant engineering) and process electronics engineer can be assigned to maintenance operations or plant engineering. Operation of a plant is ensured by having the occupation of chemicals operator, and quality assurance by chemicals laboratory workers. In the future, skilled chemical workers are supposed to perform a wider range of tasks, both on the maintenance side and the laboratory side, than was previously the case.

Within the training division, greater value is now being attached to experiential, on-the-job knowledge being added to school- and course-based knowledge. In the third year of training, every chemicals operator must now spend several four-week blocks on a production site shift. Training has also been designed for a smooth transition from initial vocational training to further training. The basis for this was the reorganisation of occupations within the chemicals industry. In the last part of the education the trainees have the possibility to make a choice between a lot of modules and only a part of them have to be covered during the education. It is new that after having finishing the education the young skilled worker can cover some modules which they have not covered during the education.

One problem encountered by in-company training schemes is the lack of suitable trainers at local level, despite the fact that foremen (*Meister* – or ‘masters’) have also trained as trainers.

The shortcomings in the training that *Meisters* receive is not so much a quantitative under-representation of educational components, but the form in which these educational elements are conveyed. During their *Meister* training, prospective *Meisters* at Company G do not practise instructing trainees with real trainees. Instead, some of the future *Meisters* play the role of trainees in simulated exercises. For the examination, two of the future *Meisters* must rehearse a role play in which they demonstrate their command of the 'Four Stages Method'<sup>25</sup> – one plays the *Meister* who is explaining something, while the other acts the part of a trainee to whom something is being explained.

The separation of initial and continuing training is an artificial separation that ties in closely with the problem of lack of training on the part of *Meisters*. When apprentices at Company G have completed their training, all contact with their trainers ceases. If they want to train as *Meister* at some later stage in their career, then this training is organised in the Continuing Training department and there is no contact with the Initial Training department. Although it is often stated in discussions that the separation of initial and continuing training has to be dismantled, no work has been done so far on breaking down the separation between trainees/apprentices, and the *Meister* who is responsible in the company for training apprentices.

### **Evaluation of learning**

The learning process of the trainers is documented in a skills database in which periods of on-the-job training are also noted. After a period of on-the-job experience, an interview is usually held with the trainer on his return, the most important results of which are recorded in a database. The skills profile of trainers for the production-related occupations is recorded in the form of a skills indicator. This is based on the extent to which the trainer masters the exercises in laboratories and technical education centres for this section of the Initial Training department.

In order to disseminate within the training division the knowledge that trainers acquire in the production plants, reports are made by trainers returning from the field at staff information meetings (held at 6-weekly intervals and involving almost all training staff).

---

<sup>25</sup> Level 1: Preparing the trainee. Level 2: Demonstrating the particular action and explaining why the work is performed this way as opposed to some other way. Level 3: Trainee imitates the action, explaining what he is doing, how he is doing it and why the work has to be done this way and not differently. Level 4: Allowing the trainee to continue working and practising without supervision. Observe and check the trainee practising

### **Diversity of forms of learning**

In order to establish a diversity of modern learning methods, a series of seminars was organized with the Heidelberg College of Education, for example, in which modern teaching methods are presented and trained (e.g. suggestopaedic methods). The Landau College of Education is carrying out an evaluation project on the subject of competence, specialized skills, and teaching apprentices.

The suggestopaedic method was also adopted by other trainers and experts and is used in on-site courses conducted by the Continuing Training department.

Other forms of learning are also planned, for example the use of video films in the production sites to communicate specific content, e.g. changing a filter in spark plugs in which the filter screens have to be stretched into place using a special winding technique.

The training division provides not only a broad diversity of course types, but also assistance with self-guided learning. After a joint kick-off meeting with a trainer, the learner continues his learning on a self-guided basis. Following the phase of self-guided learning, another joint meeting is held with the trainer to enable feedback.

One example of self-guided learning is the *Sprachbörse*, a kind of ‘Languages Shop’. These are groups on certain topics, organized in addition to the language courses offered by the training division – e.g. the groups come together once a week for English conversation over lunch, for exchanging short messages or telephone training.

### **Careers that foster learning**

For top managers in the company there is a systematically executed career that fosters learning. From the pool of new managers who join the company (usually graduates), those with the potential for top executive positions are specified. This group is regularly invited to special events organized by the training division (it is not possible to sign on for these events without such an invitation). In consultation with the head of division, the candidates are systematically appointed to any management positions that are vacated. Those employees who are not covered by collective bargaining agreements<sup>26</sup> and who are not included in the programme for top management can only get to know different divisions within the company by discussing the matter with their senior managers, e.g. in progress interviews. However, since this is always restricted to a relatively small part of the company, there is relatively little fluctuation between

---

<sup>26</sup> Employees who do not come under collective bargaining agreements are usually graduates in executive positions. The level of salary is individually negotiated and is not tied to pay agreements negotiated by the trade unions.

corporate divisions at Company G on the part of these managers. For those employees who are covered by collective bargaining agreements there exists an internal labour market.

The department heads in the training division are trying to engineer a situation in which training managers are imported into the training division from other parts of the company on a regular basis and leave again after a stay of 5 – 7 years. This aim is to ensure that experience relating to the corporate realities outside the training division have an impact within the training division. For example, a training manager for metalworking occupations was switched to a position as plant engineer. A training manager for commercial occupations was previously the sales manager for special chemicals in Moscow and the previous incumbent moved to a position as personnel planner for management.

In order to give trainers a broader range of skills and qualifications, there is a special relocation programme for trainers who run the technical education centres (chemical laboratories and process engineering laboratories). Whereas a trainer used to be able to spend his whole working life in one of the training division's technical education centres, importance is now attached to trainers switching regularly between the various centres. The breadth of qualifications is tracked by means of a qualification index. One intentional side-effect is that trainers have got to know each other better.

### **The corporate culture**

The corporate culture has changed significantly in recent years – something that is particularly noticed by employees who have been in the company for many years already and who have not changed division in that time:

“The culture has changed to the extent that we are maybe up against a stronger wind, have been given more responsibility, which I actually find very good, but on the other hand I also have a lot of freedoms within my sphere of responsibility. I think that many make the mistake of simply imposing regimentations on themselves that have not even been expressed anywhere.”  
(BKR 1776/1793)

The strength of the ‘wind’ that is blowing results from the greater demands in respect of performance and efficiency. There is more scope for decision-making, which gives rise to the ambivalent situation for workers having greater freedom in the way they do their work, while being also compelled to use this increased freedom for the benefit of the company. Some employees have difficulties mastering this situation.

Willingness to reduce the discrepancy between the company as it should be and the company as it really exists is fostered on the workforce side by the works council and

the shopfloor representatives of the trade unions. The shop stewards, for example, are said by interviewees to take constructive entrepreneurial responsibility, not only with regard to management problems or management shortcomings, but also in regards to organisation, group work, etc.

The change in the training division's organisational structure with participative involvement on the part of the workforce is viewed by some employees as a further development of corporate culture. The current state of affairs is positively assessed, especially in contrast to the situation a few years ago, when it was very unusual to involve the workforce at all.

The willingness to change rules and commonly held principles has been rather underdeveloped in the chemicals industry to date. For a long time in the enterprise we studied there was a situation in which the rules and principles remained unchanged, and if changes did occur, then these were dictated from above rather than being jointly effected changes.

A corporate culture includes a cultural basis for feedback loops enabling every manager to gain a realistic view of how he is perceived by his employees.

“How does management feedback occur?”

Depends on group size. When you've got a large group, everyone gets a questionnaire. These forms are then evaluated and discussed. Evaluation means that is the actual value, and that is the value the senior manager wants. If the actual value and the value the senior manager wants are relatively close together, we don't need to discuss anything. But if the actual value for the worker and the value the senior manager wants are far apart, for whatever reason, we have to talk about why that is. In small groups we didn't do the intensive preparation phase with questionnaires, but determined the actual and desired values more or less in talks. That was a meeting – took about half a day – then everything was OK.” (BGI 643/672)

What is interesting about the quote from this manager is the algorithmic understanding of the process that required only one intervention when there was a deviation between the behaviour the senior manager wanted and the actual value in the estimation of his workers. There is at least a possibility that an intended authoritarian management style, and one that is perceived as such by the workers, is no longer discussed because, after all, there is no deviation between the desired and the actual value.

Company G is creating feedback loops at all levels of the organisation. The biggest feedback loop is the workforce survey involving every worker in the company. In the training division there are additional feedback loops, e.g. the systematic survey of

clients using questionnaires immediately after a particular measure has been carried out, and 100 days after it.

One of the first experiences with corporate culture that apprentices make as novices in Company G relates to the behaviour of their trainers. In recent years, the Company G training division has established a personnel development concept for trainers that is characterized by the transformation of trainers, as specialized teachers for a narrowly defined subject, to trainers as learners who learn with the apprentices. Organizational measures are designed to ensure that this is not just a vision, but actually takes place. Trainers nowadays switch between the various technical education centres, whereas previously they were specialized in one. This leads to a situation in which they cannot handle everything in a particular subject and actually do have to learn along with their apprentices. Trainers should also gather operational experience again, and it is quite possible that an apprentice meets one of his trainers acquiring practical on-site experience in the same plant during one of the practical phases of his training.

### **Knowledge management in the training division**

Quality management at Company G can be viewed in a certain sense as a rudimentary form of knowledge management.

“To a certain extent, quality management functions to document organisational knowledge that we possess.” (BKA 888/899)

The quality management system stipulates a minimum level of skills for workers, independently of individual managers and their personal preferences. In the training division, in fact, organisational transformation is classed as an A-grade project in the quality management system and subjected to certain rules that relate, for example, to documentation of organisational transformation.

Another approach that can be extended to become knowledge management is the systematic rotation of employees to other jobs inside and outside the training department. Until now, programmes for systematic transfers existed for managerial staff only. The training division is now beginning to systematize the transfer or relocation of trainers. By integrating these various measures in a knowledge management system, the knowledge existing in the various plants in respect to state-of-the-art technology, corporate organisation and training requirements could be made available to training division staff.

Examples for ‘gems of knowledge’ that have been lost to the training division are the various kinds of experience that the continuing training project managers have gathered in the course of their activities. One such project manager organizes the deployment of

10-12 external instructors for a particular field. Job cuts in the training division means that there are few opportunities for joint activities in a particular field and that usually only one member of the training division staff has access to his external instructors. If one of these staff members leaves the training division, he leaves behind a knowledge gap within the organisation. A similar situation is found among the project managers, who acquire projects for the training division among their in-company customers. This relatively new field of business for the training division demands skills that could not normally be acquired in the training division until now. Although some staff members who have been successfully familiarized with the company, have acquired skills in dealing with the works managers and works employees, the knowledge they possess in this respect is not available to the training division organisation when such a staff member leaves.

In addition to building facilities that enable trainers to have jointly used offices, efforts are now being made in the training division to promote informal exchange by organizing so-called 'We-Events'. At these annual We-Events the various groups and teams in the training division provide information about their activities, rather like a bazaar, where they each have small information stands. Meals are taken together and there is plenty of opportunity for talking. These We-Events are a response to the decline in participants at previous lecture events, the task of which was to inform others about work carried out in the training division.

In another meaning the function of the "We-Events" is to re-establish a "We-Feeling" that was lost during the Focus-project.

### **Assistance with corporate knowledge management, provided by the training division**

One method of disseminating knowledge within the various enterprises is to train those with experience so that they can pass on their knowledge at work. Workshops were conducted at one site with the aim of training experienced workers to pass on their knowledge in the form of a presentation, for example. The workshops were organized by the training division with the aim of establishing this kind of knowledge transfer on a permanent basis. However, by establishing the conditions for passing on knowledge one has not yet generated the willingness to actually do so. Nevertheless, there is a substantial number of experienced workers who can be motivated purely by receiving positive feedback on their performance as communicators of knowledge.

There are a large number of very diverse, self-managed workgroups at Company G, but these have not developed into communities as yet. These workgroups focus primarily on exchanging information, but there are few ideas about how to stimulate an intra-

organisational opinion-building process based on contrasting opinions and dispute. So it seems that there is a need for developing such self-managed workgroups into communities which are able to participate for the organisational development of the whole company.

Almost all the training division's course material can be downloaded over the Intranet. For example, there is a course entitled *Praxiswissen Betrieb* ('Practice-related Knowledge of the Plant') in which process engineering fundamentals for a chemicals plant are described and explained, e.g. the various kinds of pumps used at Company G. The course materials, a small brochure with figures and texts, can be downloaded from the Intranet by any Company G employee.

### **Learning from others and/or the environment**

#### **Training**

Apprentices and trainees in all fields regularly visit partner training centres of Company G throughout Europe. There they are confronted with entirely different training conditions and other cultures, and in this way are encouraged to reflect on their situation in Germany.

Staff in the training departments of the big chemicals companies maintain contact amongst each other and inform each other about trends and developments in their respective companies. There are also presentations and pilot projects in chemicals companies (Wacker and Hüls), that attract the attention of chemistry trainers.

Part of the information that Company G employees receive about the situation in other, similar chemicals companies is from external trainers who hold courses in these other companies as well. In the training division there are often students on internships, e.g. from the near-by universities of Mannheim and Heidelberg, and dissertations are written that compare the training division at Company G with the training division in other companies (e.g. VW).

Company G also maintains contact with other companies in the surrounding region, for example with DaimlerChrysler, and expresses the topics that are being discussed there. For example, there are workgroups of training division staff within Company G that prepare group work on particular topics. One topic was current activities in the field of in-company continuing training, for example at DaimlerChrysler. Congresses and trade fairs are also visited on a regular basis, one example being the Lerntech fair.

The initial training department at Company G compared itself intensively with the vocational school in the German site. The latter is virtually a Company G school, due to the large number of Company G trainees there, except that it is run by local

government. One consequence resulting from the comparison was the reorganisation of course content. Whereas many things used to be taught parallel in both places, the system now applied is a division of labour in which each training site covers certain topics in full. For example, the subject of pneumatics was completely covered by the vocational school, whereas the subject of CNC was completely covered in the initial training department at Company G. The comparison included a look at different teaching methods as well. Trainers from Company G will now switch for six months to the vocational school, and vice versa, in order to learn each other's methods.

The initial training department at Company G also compares itself with smaller companies in the surrounding area. In this comparison, interest is centred on the practical relevance of training for the work process that the companies must necessarily establish without a central training division. These companies practise on-the-job training that is still viewed as unthinkable by many parts of Company G due to the fact that Company G has only little experience with training apprentices in the actual plants.

What is particularly interesting is the comparison with the training division at Aventis (formerly Hoechst AG). In the days when Hoechst AG still existed, the training division was completely separated and re-established as an independent entity called 'Provardis'. The customers of this independent company are primarily the many different companies at the Hoechst site in Frankfurt. In addition to Aventis, there are many companies there that were similarly separated from Hoechst AG. One reason why Company G staff have intensive contact with Provardis is because the development of Provardis can influence the decision within Company G on whether or not to separate the training division. Benefits are seen in the considerable independence enjoyed by Provardis staff. Disadvantages are seen in the lack of any integration with the production sites, which would make it more difficult for trainers to have periods of practical on-site experience in the production field. Other disadvantages are seen for the in-company training phases, because training officers in the companies are separated from the training company Provardis by a corporate boundary. Handing training to an external service provider fosters neglect of the company's own responsibility to provide in-company initial training.

Experience is exchanged with Infracor (the former training division of Hüls) in the form of trainers sitting in on classes. Twelve to fourteen trainers from Company G spent a week at Infracor in Marl, where they took part in lessons. Conversely, trainers from Infracor came for a week to Company G. Such exchanges take place on a regular basis.

Company G also participates in CEDEFOP exchange programmes. For example, one interviewee attended technical training institutes in Denmark after the Bertelsmann prize went to that country.

In the course of restructuring the initial and continuing training division at Company G, a business consulting firm carried out a benchmark analysis of the training operations at Company G and other major companies, such as DaimlerChrysler and Lufthansa. One specific result of this comparison was the re-evaluation of the support trainer's role, i.e. the person who accompanies apprentices over large sections of their training and plays the role of teacher vis-à-vis the apprentices.

With the aim of gathering ideas for training from a field beyond that of initial vocational training, courses were held with youth educationalist who presented suggestopaedic methods. For instance, joint involvement by trainers and teachers was felt to be particularly productive.

Visits by apprentices and trainers to other Company G sites in Europe, like Tarragona in Spain, are useful not only for getting to know a different culture – the visits involve joining in and taking part in order to get to know other ways of working and training in more intensely.

Executive staff at Company G in the German site are also sent for example to America to learn the management method called Business Process Reengineering by working for one or two years on restructuring projects.

### **Conclusions**

The development of the organisational project focus caused a heavy economic pressure and brought about an intensive examination of all organisational routines, methods and structures within the department of education. The organisation was tightened and many new, and for the trainers, strange elements were introduced. About the participation of the trainers a contradictory picture arises till now: some of the interviewed persons insinuate dishonest behaviour to the management. E.g. the goal of the support trainer should not be what the management claimed – a decrease of the drop out quota – they assume that the real idea is to pressure the trainers to teach the whole breadth of the profession instead of parts which they can specialize in. To this explanation fits, that this is actually a professed aim of the management. What does not fit is that the management has made not kept these aims secret in the interview, but rather, explained in detail that trainers will be made job ready again outside the education department with a few measures. One of the interviewed remarked that the staff cuts were hard to make because it was difficult to rearrange trainers into other parts of Company G; they

don't have the qualifications required. Some of the instructors who were interviewed by us stand behind the measures of the management and share their opinions. But there is obviously another part which wasn't interviewed yet who does not share these opinions.

At this stand of our investigation it is possible to say, that the first criterion is fulfilled, but it seems that the participation of the staff is in need of improvement.

Without any question there exist a lot of learning methods within the training division and organisational measures which have the aim to improve the learning of the staff. Our impression is, that these measurements are mostly influenced by the economic pressure and that there is not a real organisational inquiry about the advantages and disadvantages of the measures. For instance: Is it very beneficial that the trainers rotate between different positions in the training division and teach all areas of study? Some trainers argue that this leads to a surface knowledge which is less useful than up to date specialized knowledge. The question for our further investigation is: How does the organisation deal with this theme?

The education department has gone through a deep change and a number of old patterns of behaviour have been checked and questioned. But the question here is whether the readiness for organisational change has become part of the corporate culture.

Since the Focus project you can talk about the fact that the readiness for the organisational change is part of the company culture in the division of education. It was the staff of the division themselves who have changed large portions of the organisation. However, in our investigation until now it is not clear how much room the employees had to work with realizing the goals of the management because we received contradictory statements concerning it.

There are at least some employees who do not feel personally responsible for the further arrangement of their organisation but wait for things to come their way. Other interview partners became conscious, that they have won new scopes of action in their work and they try to use it. On the basis of our investigation until now, we think that the department of education has developed a corporate culture in which transformation is a living part, but there is still resistance against transformation.

The knowledge which is needed for the knowledge management is about the work and business processes of the training division. The knowledge which is taught by the trainers in a standard course is then the object of the knowledge management system, when a change in the organisational bound knowledge is necessary. That can be the case when a new view on and a new attitude to the teaching content appears. If the organisation wants to improve the lecture in a way that the relation to the work

processes is enhanced, then it is necessary to find out new forms of teaching and not only new contents.

Our impression is that the different subdivisions of the training department are only in weak contact with each other. There is a great borderline between the subdivision for initial training and the subdivision for further training. The reason for this borderline is twofold: firstly there is a spatial separation, both subdivisions are in different buildings in different locations; secondly the subdivisions are different parts of the organisation each with their own manager. Both facts makes it necessary to establish a knowledge management system.

Within the different departments the knowledge which should be the object of knowledge management is the knowledge about the handling of new business responsibilities. It seems to be that some of the employees have gotten quite used to the new business fields. The interchange of their personal knowledge with the organisational knowledge base seems to be low. There is danger that much of the knowledge of these employees will not become organisational knowledge.

Knowledge management in a learning company is more than an information exchange and so it seems that this criterion is not yet fulfilled.

In the context of the focus project "learning from others" was operated through a professional benchmark. For example, the support instructor and the consistent orientation of the organisation at business processes is a result of this kind of learning.

This orientation to business processes also can lead to disadvantages. The question whether the organisational learning process has gone beyond the studies of the allegedly best examples by "the comparison with others" therefore arises.

Has Company G learned something from the comparison with other education departments about its own strengths? Or was the main focus during the comparison only on the sides of the fellow applicants which seemed better than their own organisation.

Since "learning from the environment" is operated at different levels, it seems to us to be justified to look at this criterion as fulfilled. But the "learning from the environment" still can be developed further.

### **3.5 Case 4: The master as a catalyst in organisation learning**

In the preceding cases of organisational learning, organisations and subdivisions of organisations, respectively, were introduced. The following two cases refer to specific functions and roles, respectively, inside the organisation: The master craftsman (*Meister*) and the instructor (*Ausbilder*).

In Germany, both roles are closely connected to the vocational-training system and are therefore suitable to study the connection between the company concepts of organisational learning and the concepts of the national organisation of education and training.

The master<sup>27</sup> plays a key role as a catalyst in the further development of organisational learning and actually not only in single factories like the sulphite factory or the steam cracker, but in all factories of company G. Therefore, the role of the master for organisational learning should be discussed in a separate case.

### **What function fulfils the master craftsman in a chemical factory?**

The industrial master specialised in chemical technology could have two important functions in the factory: First one is the shift master or shift leader and the second one is the day master. Among the superiors of the operation of the factory, we find industrial masters with specialisation's in metal technology, electrical engineering/electrical technology and electrical engineering/measuring- and controlling-technology. In the following we deal, however, only with the industrial master with specialisation in chemical technology.

#### **The shift master (shift leader)**

The tasks of a shift master include:

- The operation of the chemical factories
- Supervising and instructing maintenance work
- Educating and instruction of new workers
- Safety instructions
- Encouraging of shift workers (selecting the candidates for training as chemical assistant, operator and master craftsman, respectively)
- Planning of tasks

The shift masters shape the culture of the shift in a stronger manner than is recognised from this list at a first glance. The term "culture" refers here to the soft factors of the organisation of the work, hence, topics like way of speaking, trust, climate of learning, the openness to criticism, the encouragement to learn, possibilities of further training and so on. The hard factors of work organisation are on the other hand: Description of

---

<sup>27</sup> In Germany exist two forms of master: the master craftsmen in the trades (i.e. trade of baking or tailor) and a industrial master. In the education to the master craftsperson value is added that the master learns to lead a business independently. The industrial master work as a employee. In our study we focus on the industrial master.

the employment position, qualification demands, entry-qualifications, disciplinary directives and so on.

The distinction into hard and soft factors is made here, because the demands on the master craftsmen have been drastically increased, especially in the field of the soft factors. For example, it is taken for granted that the shift master knows his factory in detail and can judge malfunctions that appear. During the weekend and at night, the shift masters are the highest ranking staff in the factory and they have the full responsibility for the safety of workers, the factory and the environment.

The matter of course that the master craftsman has to have high-specialized knowledge of his subject and a high level of experience, before he can start to work in his position, has hardly a correspondence in the field of soft factors. It is not taken for granted in the same extent as in the field of highly-specialized knowledge and experience that a shift master is, for example, able to motivate his workers to learn and to encourage them to make proposals for improvements. In the last years company G has recognised that staff cuts have to go along with the development of these soft factors among the master craftsmen (but not *only* among them). In the past, master craftsmen have more dominated instead of led their workers. Especially among the older shift masters, we found a more declining attitude towards seminars on leading workers.

“Interviewer: Why don’ t you think much of the seminars?”

Master craftsman: Because the people who stand in the front and present their seminar paper are only theorists. If I have a worker who knows exactly, when he has to wear a helmet or protection glasses and I catch him while not doing it, then I will tell him once, two-times, three-times. But at some point, it is over, and he has to be punished. And if you then hear from the people in the seminars what kind of suggestions they have... you want to tear your hair out.

Interviewer: What do you suggest then?

Master craftsman: To give time and attention to the man; not to raise the voice. If I call a man in then he knows exactly what I want from him. And if I tell him you mustn’t do that, then he says: No, I won’t do that any more”. And he has done that ten-times. And if I don’t react, then he does that 20-times if necessary. So sometimes I have to say that is the limit, and now we are going to the next room [to the day-shift master] in order for him to be punished. They [the instructor of the seminar] don’t want to hear that” (UCZ618)

Here the idea is that the shift worker has to be punished if he does not obey. Among the young shift masters we did not find such an attitude any more.

### **The day-shift master**

The day-shift master is the superior of the shift master. His tasks involve:

- Taking care of and responsibility for the workers of the day shift;
- Coordination of the shift;
- Assigning work assignments to the shifts;
- Coordination of the workers of other sections and the workers from the department of maintenance;
- Checking safety regulations;
- Planning and organizing of factory changes and maintenance;
- Releasing and controlling costs of tasks that are connected to orders of material (for example devices, pipes etc.);

The day-shift master is very busy with planning and checking. He is therefore dealing less with the workers of the shift. Operating the factory is the main task of the shift master, while the day-shift master is occupied trying to guarantee the prerequisites for the operation of the factory. Planning, organizing and coordinating mainly define the work of the day-shift master, while the shift master operates the factory together with his workers, supervises and coordinates and supervises activities directly in the factory.

But the job of the day-shift master has also changed during the last years. While the day-shift master still works quite autonomously today and the management and the factory assistant check his activities only from time to time, his job was lacking independence a few years ago:

“Interviewer: “And when have you become day-shift master?”

Speaker: “Actually, that was a continuous process. I came to the day shift and practically from that time on I had the operator’s degree I was working in that position. But, to have the position nominally and to get the acceptance from the various workers of the shift are two different things. Actually, I had the position of a day-shift master and the payment (...) but I was not able to really fulfil the position. Only after the older colleagues left I suddenly had the responsibility and I also had somebody in the management who also knows how to stop the appearance of that acceptance. Hence, it comes at some point. But now I would say I have been completely in charge for 5 to 6 years, although I actually did the same job before. But as I said I did not have the acceptance and the power to make decisions, I always had to be my own back up. Today I can make decisions that are backed up from the top.”(SWI41-157)

The process of delegation of responsibility down through the different levels of hierarchy has to be accompanied by a culture change. To have a position nominally and to really be able to fill it out are obviously two steps that can take a long time. The fast practice of the management to change titles, functions and responsibilities in

organisational charts is followed by a sluggish company-practice where the newly allocated rights and functions in the daily lives of the company become slowly effective.

### **Education to become a master and for the master**

The new tasks of the master already have their correspondence in the Curricula of the industry master education: The block "employee leadership" in the first step of the education to the industry master has 72 of 578 hours (= 12.5%) lessons. However, the qualification needs of the future masters still are not covered. After completion of their examination for master diploma and after beginning their operational function as a shift leader (or also as a day master or master in the department of maintenance) it is understood that the masters continue in seminars for the leadership of the staff. There are a sequence of four seminars:

M1 – The master craftsman as a leader

M2 – The master craftsman and his team

M3 – Co-operation at the location

M4 – Master of change

The prerequisite for participating in the seminar is actually not the degree of a master, although the title of the seminars shows definitely the tradition to send only masters to such seminars. We have done a participative observation of an M4-seminar and found there were only masters there anyways. The average age was relatively high; only two participants were between 30-35 years old, the others significantly older. Many were around 50 years old. Each seminar lasts four whole days and takes place in a conference hotel outside the town in a pleasant surrounding. Ideally, a master could pass these seminars in two years and could have passed them already in the position of deputy shift master. In the weekday of the factory the lack of well-educated workers caused the masters to cancel confirmed participation in a seminar because of company demands. Among the participants of the interviews, we had a master who has been working for 9 years on his current position and has not yet participated in all four seminars.

### **How to become a master?**

Until October 2001, 8 workers have participated in our company interviews who either had the company position of a shift master or day-shift master, or who had passed the education of a master craftsman. In one plant we found two shift masters without degrees as operators or master craftsman, while in the other plant 5 of the 6 shift masters had finished their education as master craftsmen. Company G appoints very

experienced workers to master craftsmen (so called appointed master craftsmen) in times, where workers with formal qualification can not be found.

The path from novice to master craftsman leads typically over two steps. The first step is the position of a skilled chemical worker. Almost all of the interviewed workers in the position of master craftsmen have started as shift workers specialised in other subject areas. Two of them had, for example, a vocational profile in the business field, the others vocational profiles in metal- and electrical engineering. All of them became skilled chemical workers as a second vocational profile within company G. The training for this was done in company G in day-shift on two or three weekdays and was typically finished after two years. Workers who get this offer by the company have in general proven themselves during few years on shift. From the perspective of shift and plant management, the skilled chemical workers have the potential to become a foreman (shift leader) or a deputy shift leader.

The education to become an industry master craftsman specialisation in chemical techniques is done according to a nation-wide accepted curriculum in training centres of company G. We have participated in observations there, too. The education is widely done by subject-intensive lessons in a didactic teaching (Frontalunterricht) interrupted by some project-like phases. The education is done in two steps: The first step ends in the title "Operator – chemical technique" and is a special case, which only exists in the company appropriate Chamber of industry and commerce (IHK). The second step ends in the title "Industry master subject area chemistry". The first step is done in a time period of two years accompanying the work (for every three weeks work there are five training days at maximum), if the future master does the training with the invitation of company G. Every workers who passed professional training and has at least two years of company practice is free to attend a training course at the IHK or any other provider of training courses in his spare time at his own costs and to get the master degree on his own initiative. However, among our interview partners, this occurred only once.

### **The master and the organisational learning**

In the following content, it should be clear what are the reference points between the master and the organisational learning. We use our project criteria for this purpose.

### **The master and organisational procedures**

Many organisational procedures are a part of the fields of responsibility of the master, such as regulations for job sequences, safety regulations, regulations for inside working staff from external companies or for the staff from the internal department of maintenance. We have constituted at least two procedures of the masters for the way, in

which they control their worker to obey these regulations. One can describe the first one of these methods as the authoritarian method. The master insists that regulations have to be adhered and refers to the punishments threatened in the case of the breaking the rules. The second method can be described as the explanatory method. The violation of rules and regulations is also to rebuke, but the reason for the regulations will be explained by the master. During a participatory observation, we accompanied a representative of the second method. During his obligatory tours throughout the steam cracker, he illustrated and explained to the novice the regulations and rules and furthered the newly learned topics by assigning small tasks.

From the point of view of organisational learning, the strong position of the master has two sides regarding the shaping of organisational methods. On the one hand, through qualification and training, the master can be convinced of the new organisational methods and act as a multiplier, in this way the master protects the learning progress of the learning company; on the other hand, the dominance of the shift master impedes the shift worker to develop themselves into a problem-solving group. If one regards the dominance of the master and his strong position as necessary in the chemical industry (the reasons would have to be discussed), then he or she must establish procedures which take care that the masters don't individualise their management styles too much. The seminars the masters take part in provide them a good opportunity to look beyond the limits of their plant and to recognise their own style of shift management. The shift masters of a plant should agree with each other about the minimum conditions for management styles and for the further organisational development. Till now, this wasn't the case and this can be covered by the discussions about the preparation of the plant manual at the Steamcracker (see p. 77)

### **The master as trainer and coach**

The master in his role as trainer and coach is an important authority for the shift novices' learning. At the steam cracker, one has recognised this meaning and tries not only to give the novices new learning possibilities with the project "active learning", but also to educate the masters to use a variety of new and old teaching methods. The masters should be able to support the novices in their development more effectively.

At the effort to orient the learning processes strongly to the actual work processes, the master has a double function. He is the authority who makes the novices familiar with the work processes in the chemical plant. Thereafter, the day and shift masters look after the trainees who come into the plant during their education.

In our opinion, a deficit consists in the training of the master for such educational tasks. We carry out a participatory observation during the so-called "education of the

instructors (AdA)", for example. This is a section during the master education, in which the masters learn how to train the trainees. This was carried out in a way that a participant played the role as trainee and another one represented the instructor. Both carried out a fictitious conversation about an experiment which is a component of the education of the trainee. The consequence is that a master should be able to train trainees by such simulated exercises without having a real contact with a trainee.

This manner of the master education has actually been obsolete from 1999 on, since there is a new statutory order about the master education, and the described method is only practised in a transition period. The new ordinance is discussed as learning from others, named by the professional educational system in one of the next sections.

### **The master and the culture of the company**

Enterprise G went through a internal cultural change which is induced economically. During the last few years, staff cuts have been leading to a shift of working tasks from the top to the bottom. That means a delegation of tasks and responsibility from above to below is observable in almost all parts of the industry. The culture change associated with this responsibility shift concerns the manners of the different hierarchical levels with each other and shows a change of the ideal images of the different roles in the enterprise. The employees are no longer regarded as recipients of orders but respected as central and valuable resource for the development of the enterprise. A central organisation unit of enterprise G carries out regular employee surveys in which the employees are asked to judge their immediate superiors, for example. The masters have to face the judgement of the workers and have to understand that their authority can not be based exclusively on their position any more. For example in the seminars for the further education of the masters (M1-M4), the masters become practised in using methods of judgement of themselves through their workers and superiors (e.g. the method "self picture/some one else picture" in which a questionnaire about the communication behaviour is filled out by both the master and a participant of the seminar co-operated with the master). From the differences between his own and the external assessment of his communication behaviour, the master should learn to be aware of himself more objectively.

This change of the enterprise culture is not joined in by all masters. Some of the old masters are rather suspicious about the new role of the master. One female psychologist, who moderated the preparation of the plant manuals, reported to us that a master complained to her that after the shift worker had taken part in writing the plant manual, they became more self-confident and asked more questions than the master was able to answer.

### **The master and knowledge management**

Since the shift master is usually one of the employees who has been working for a long time in the company, he plays an important role in the passing of knowledge which is necessary for operating the plant. The meaning of this role was reduced a little by an organisational measure, namely the documentation of large portions of the knowledge about the plant in the plant manual. Now, an information source independent from the master exists for the employees and a new employee could theoretically qualify himself through the plant manual and determine his career. In the practice, one does not notice so much of this, since most of the workers still learn by communicating with other workers and/or the master. In addition, it is still rather the master who stimulates his employees to learn and advises them to read certain sections of the plant manual.

The operator manual can be interpreted as a measure of the enterprise, for transforming the position of the master. The aim of this transformation is the new role of the master as coach and trainer. The central organisation of the continuous improvement which shall support the creation of new knowledge at the level of the workers also contributes to the transformation process of the master. The improvement process was already described. The management has established the possibility to submit suggestions for improving to a central unity. This makes it possible to submit suggestions for improvement independently from the master and the management. This measure can be interpreted in that the company does not want to just rely on the masters and plant managers have already worked enough to activate improvements.

During a participatory observation of the work of a day master, we could watch the processing of a suggestion for improvement. The suggestion for improvement provided that a new valve in a certain place of the plant shall be installed, so that the work can be made easier and faster. The day master explained to us the consequences not considered in the suggestion for improvement from his point of view. If one realises the suggestion, it will be necessary to build up scaffoldings before carrying out the work. In the opinion of the day master, the suggestion for improvement would immediately make the work easier at the valve, but require additional preparation work before that. After his verdict, the suggestion for improvement would bring nothing in the end, and he would like to therefore decline it. He must justify the rejection in written form and has to talk with the worker. The day master assumes that the worker will criticise the rejection of his suggestion for improvement as an arbitrary act. The payment for successful suggestions for improvement doesn't contribute to the de-emotionalisation of such conversations at all, since the reward escapes the employee by the rejection. The master is therefore definitely in a conflict if he, on the one hand, shall activate suggestions for improvement; on the other hand, however, he must turn down suggestions which don't

represent any improvement in his eyes. The master has only to be released from this conflict when the payment of suggestions for improvement is changed.

### **The master and the learning for others**

It has been already mentioned that the employees of the different plants are relatively strongly isolated under each other. However, the masters have some possibilities to fetch suggestions out of other plants. But these possibilities are hardly used apparently. There are meetings at least once a year to which the masters every department of the enterprise (such a department consist of i.e. 20 to 30 plants) are invited. The department heads use these meetings to report about the development of the department and the complete enterprise. It is our impression from the interviews that the managers provide information merely and do not have a real feedback at these meetings.

With respect to the master education, learning from others takes place anyway. The master education is namely not only a thing of company G, but it must also hold on to certain framework conditions, as they also play a large role in the education of the trainees. We talk about training ordinances, in which the contents of the examination for master craftsman's diploma are fixed obligatorily. These training ordinances are regulated by the Federal Ministry of education, science, research and technology by statutory order together with the Federal Ministry of economy. The reorganisation of the examination for master diploma took its starting point at the quick change in the role of the master in the metal industry (particular in the auto industry). In the eighties computer-assisted technologies were introduced and even new organisational models, such as teamwork. Both caused an erosion of the power of the master role as it was accepted at that time. The change of the function of the master resulted after long discussions in the reorganisation of the master's education. In the chemical industry, this process hasn't taken any course which was so spectacular and was not taken into account by science. Now the master education in the chemical industry profits from the discussion and the development in the metal industry, because the reorganisation of the industry master in metal technology served as a model for the reorganisation of all the other master education. In this way the chemical industry can profit from the experiences in the metal industry.

### **3.6 Case 5: The instructor (Ausbilder) as a interface between organisation and the system of vocational education**

The role of the instructor has already been examined in the section about the education system of company G (see p. 96). In the following, we look at the instructor as an interface between vocational educational system and in-company-training.

The role the instructor plays for learning in the company turns out more minor than one would suspect at first. Although the instructor is busy with education and learning processes and shapes the trainees of a vocational profile by teaching contents and arrangement forms during the time of the education full-time, the influence on learning in the company remains relatively small. At first large portions of the complete education of the trainees take place isolated from the rest of the company. The commercial technical trainees go through education sections in the plants only toward the end of their education, and only then they get to know the reality of business. The instructors are almost not involved in the organisation units for which they train the trainees. This condition also becomes criticised in enterprise G, and it has started to change the situation by organisational measures.

A double role falls to the instructor: He is the employee of the education system on one side and by his work this organisation unity is able to fulfil its order. Since a greater importance is paid to the attention to the economically meaningful use of the labour, the role of the instructor as a factor worth creating for the department of education, and training becomes more important during the last few years.

On the other side, it is the task of the instructor to prepare the future work force of the company for its role in labour in the enterprise. To this end, it requires not only the arrangement of the technical competence but also the social and communicative competencies which only make a smooth transition possible from the department of education to the production and services sectors of the enterprise. During the education, the chance exists that the trainees can reflect upon their role in the enterprise while later the time for reflection is limited by the work. Not only time is required for this reflection process, but the trainee must be clear about the expectation of the plants. If they had made experiences in the plants, the education department can help with the theoretical classification. Participation of employees in a learning company is expected to lead to substantial progress in the shaping of the company.

To achieve this goal a new organisation model for the department of initial and further training was realised with the initial training as the process on which the organisation has to focus (see case 3, p.96). The Training of trainees follows a new idea: integrated education (“Ganzheitliche Ausbildung”) and this organisational measure has meaningful consequences for the instructors. The instructors are not only responsible for a class of trainees (as in the past), but have to work very close with their trainees. They have to teach their trainees in a very broad field (with more subjects than in the past) and have to visit them in the school and in the plant. The instructors now should be responsible for the whole education process and have to check that the goal of this process is reached.

So, the idea of a good trainer changes: In the past a good trainer knew a lot of the specific knowledge (the ideal instructor was an expert). Now the trainer should be the person who is in charge of his trainees (Betreuungsausbilder) and he or she has to develop his trainees (in German: the instructor should be the „Coach“ of the trainees). In former times the training ordinances in which the curriculum for the vocational profiles is fixed had the status of a bible for the instructors. They tried to teach the complete list of topics. Now, what is really needed in work processes becomes much more important and the training ordinance had lost its character of a detailed list of topics and is more like a frame in which different possibilities can be realised. The instructor now has the task of making an interpretation of what is obligatory by the training ordinance and what is needed in real work processes.

To do this, the instructor has to analyse real work processes and to draw conclusions for the education process. To be able to do this, the instructor has to learn what the demands of up to date work processes are. The organisational measure is to send the instructor to the plants, let them make participative observations during a practical training in plants: The instructor experiences the real work situation in the plants and work shops. But it is the task of the instructor to draw the right conclusions for the education process from his or her experience.

The instructor has to undergo a development if he wants to meet the new demands. From the site of the company this development is accompanied by a personal development program for the trainers in which a new concept of competencies was developed. Actually, we analyse this topic and do some more empirical work in this field.

### 3.7 Literature

- Boreham, N.C.; Samurcay, R.; Fischer, M. (eds.): *Work process knowledge*. London: Routledge, 2002.
- Fischer, M. *Bildung als Kernbereich des Unternehmens? Betriebliche Strategien im Umgang mit der Berufsbildung*. In: Haase P.; Dybowski G.; Fischer M. (eds). *Berufliche Bildung auf dem Prüfstand. Alternativen beruflicher Bildungspraxis und Reformperspektiven*. Bremen: Donat Verlag, 1998, pp. 109-126.
- Fischer, M. & Röben, P. (eds.) (2001) *Ways of Organisational Learning in the Chemical Industry and their Impact on Vocational Education and Training. A Literature Review*. ITB-Arbeitspapiere Nr. 29. Bremen: Universität.
- Mariani, M. *Work process knowledge in a chemical company*. In: Boreham, N. C.; Samurcay, R.; Fischer, M. (eds.). *Work process knowledge*. London: Routledge, 2002, pp. 15-24.

---

*Michele Mariani*

## **4 Cases of Organisational Learning in the Company I (Italy)**

### **4.1 Site under investigation**

The site under investigation holds a 40 year long world leading position in research, development (R&D) and production of polyolefins, which are the basic components for a wide range of plastics<sup>28</sup>. It is part of a global company<sup>29</sup>, the world's leading producer of polypropylene and the fourth largest producer of polyethylene.

Unlike any other chemical company in Europe, the site reached its maximum occupational level (5.000 workers) in the sixties, when chemicals were a highly profitable industry (Bordogna, 1989). In the years the introduction of highly efficient new production processes and ever increasing competition in the global market have led to a progressive reduction of workers in production. The occupational level within the research and development division of the site has always been stable if not increasing.

Actually, the site as a whole employs about 900 workers in about 20 departments, the majority operating on a continuous 24 hour basis. The site is split in two main divisions: Manufacturing, and Research and Development (R&D). Manufacturing employs about 200 workers, is devoted to the production of large quantities of chemicals, and is further organised into five departments:

- Management
- Maintenance and Engineering

---

<sup>28</sup> Beside R&D and production, other activities concern the provision of services for customers (co-design, piloting, computer aided design, compliance testing, etc.), and the delivery of technologies (catalysts; process for the production of polypropylene homopolymer, random copolymer and heterophasic copolymer; low-pressure slurry process for the production of unimodal and bimodal HDPE; etc.).

<sup>29</sup> The Company has customers in more than 120 countries and operations in 26 countries across five continents.

- Logistics
- Services
- Production Plants

R&D employs about 700 workers, is devoted to research (new products and technologies), and is further split in six more departments:

- Management
- Business Support
- Technical Services
- Laboratories
- Pilot Plants
- Catalyst Plants

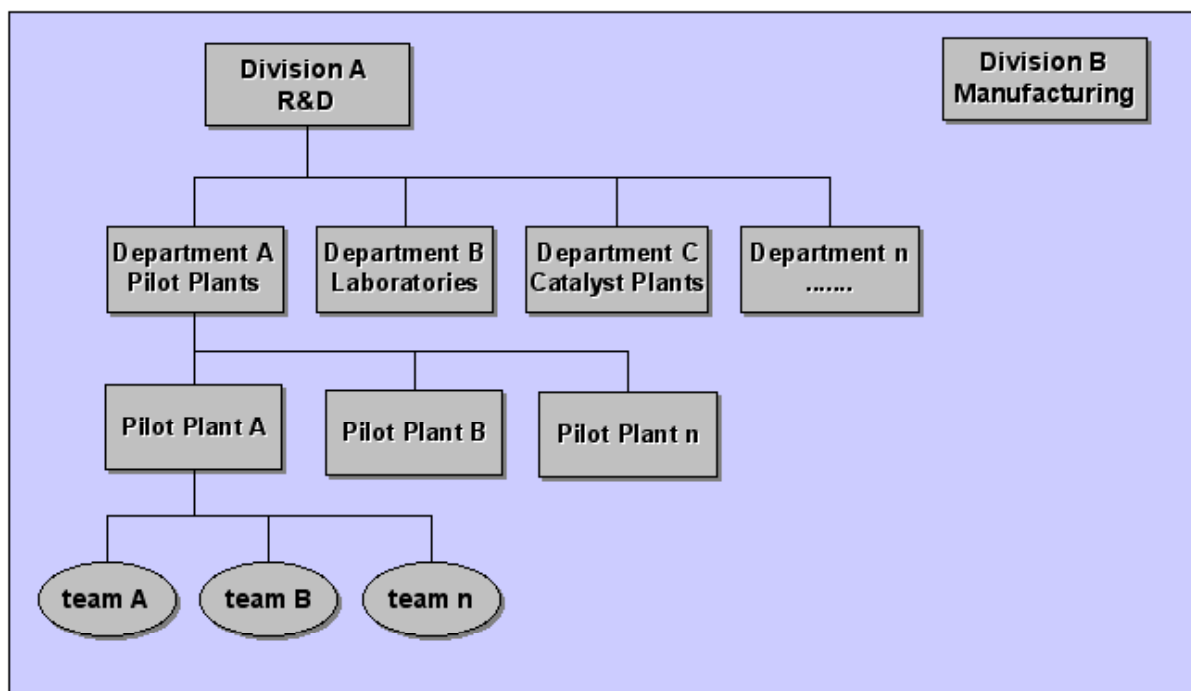

Figure 16 Simplified organisational chart of research and development (R&D).

On the production side (Manufacturing), the actual limited capacity of the market to absorb polyolefins surpassed competition on *efficiency*, i.e. trying to produce the same quantities of product with less resources, at lower costs. Such a result is actually pursued by the adoption of two main strategies: i) streamlining all parts of supply chain (from procurement to product delivery), and ii) applying best practices in compounding facilities.

On the research side, the challenge resides more on *effectiveness*, that is on the capacity to perform more experiments in less time, to get the product faster to market. To reach this goal, two main strategies have been adopted, namely: i) joint development of both products and processes, and ii) adaptive planning. The adoption of these two strategies led to outstanding results: with a very small increase of personnel Pilot Plants performance grew from one test every month (early '80s) on one installation, to two tests per week in three installations. Thanks to the introduction of continuous cycles of work (24 hours) laboratories' activity shifted from 2-3 tests per day to 20-25.

Given that R&D (see Figure 16) is the most advanced in terms of organisation of work, it's strategies and their relevance in terms of Organisational Learning will be the focus of the report.

### **Research process**

The research process has three key features, namely: i) it is staged in three interconnected phases that allow the joint development of product, technologies and processes; ii) it is adaptive, that is its planning can be changed as a function of new needs or discoveries; iii) it is managed by teams.

New products are developed at *three stages*:

- testing in very small reactors in the Laboratories
- testing in scaled down plants (Pilots)
- (eventually) production in Manufacturing and Catalyst Plants

The process is staged because once a new product/reaction has been successfully tried in the small reactors of the Laboratories (e.g. a new catalyser becomes a polymer), it is not convenient to transfer the same reaction directly to large scale industrial plants: the production process itself has to be tested first. Such testing takes place in the Pilot Plants<sup>30</sup>, which are also necessary to produce macro samples for testing the qualities of the new product. A key characteristic of the site, thus, is that the phase of invention of new chemical components is deeply merged with the phase of experimenting new technological solutions for the production of the components themselves. It is a *joint development of products, technologies and processes*. The new catalysts coming from Laboratories go to Pilot Plants which produce samples that give indications both on the changes that have to be brought into the recipe and on the changes that have to be

---

<sup>30</sup> Catalyst Plants are similar to Pilot Plants, however, they are more devoted to production than to research. Trials and errors on these plants can be very costly (precious products lost).

brought into the technical process. The whole cycle is repeated to a satisfactory result (see Figure 17 below).

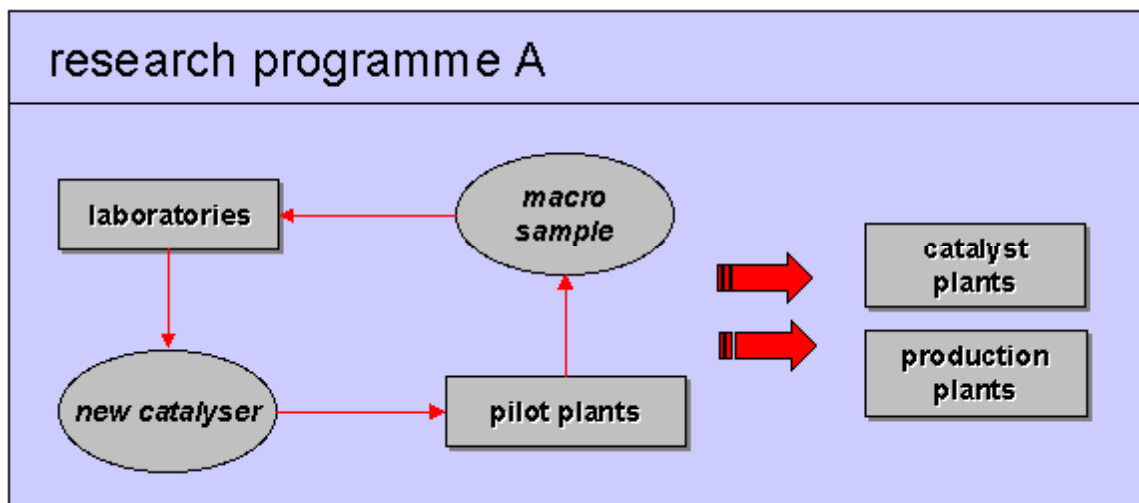

**Figure 17 Representation of a sample research programme. Research processes mainly involve Laboratories and Pilot Plants. Once a new catalyser has been successfully experimented in the Laboratories, it goes to the Pilot Plants that have the double function of both testing the production process and of producing the macro samples that are needed to test the qualities of the new materials. The process can be repeated a number of times to both refine the chemical recipe (in the Labs) and to refine the production process (in the Pilot Plants). Once the results are satisfactory, the new product goes to the large scale Production and Catalyst Plants.**

The research activity is made up of different research projects. The scheduling of the research projects to be performed is defined by a mixed committee made up of researchers and people from product development<sup>31</sup> that meets each four months. Along the meeting, a list of the research programs to be performed in the next four months is defined and the different components of the organisation (installations, materials, workforce) are aligned accordingly<sup>32</sup>.

<sup>31</sup> These people keep contacts with clients to both understand if there's market for a certain idea and to get orders.

<sup>32</sup> Organisational functioning is goal-based: The organisation configures itself as a function of:

- research programmes to be developed;
- product to be delivered;
- services to licensee plants.

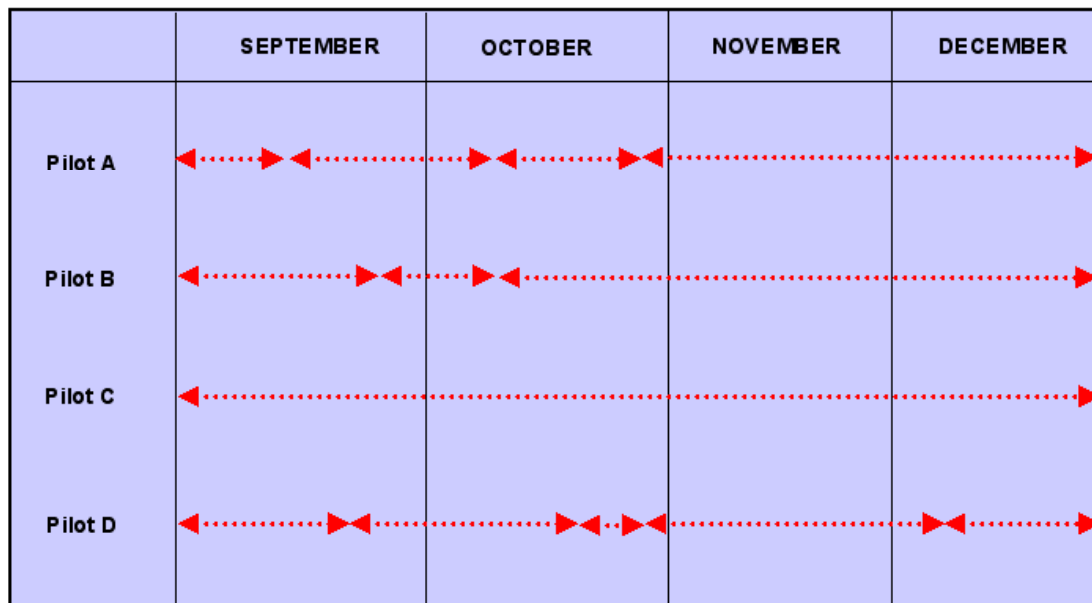

Figure 18 An example of the four-month research activity plan as it is represented for the Pilot Plants. The arrows indicate the duration of each project (the names of the projects have been dropped for confidentiality reasons).

Planning is *adaptive* because the general program can be changed before the four month period has passed. This can happen because:

- a new promising project arises
- some ongoing programs give results which are very different from what was expected
- some programs end earlier than was foreseen

Especially with respect to the last possibility (programs ending before the foreseen deadline), the complete list of research programs is organised in priorities. Beside the projects on the plan, other projects are put on a kind of wish list so that they can be inserted in case of vacancy of a plant.

The whole site activity is managed by *teams*, at both an operational and a managerial level. Such teams can be either permanent or temporary. As it will be relevant for the discussion of the different practices, the composition of a team in a Pilot Plant will be herewith briefly outlined.

Pilot Plants are operated by teams working on a continuous 24 hours basis<sup>33</sup>. Four basic roles can be identified (see Figure 19)<sup>34</sup>:

<sup>33</sup> Three shifts of 8 hours each (6-14; 14-22; 22-6).

<sup>34</sup> A Pilot Plant can have about of 20 employees. Both the number and the competencies of people who constitute a team can change depending on the complexity and the intensity of the process. For example,

- plant/division manager
- plant manager assistant
- shift leader
- multiskilled operator (operatore polivalente di impianto)<sup>35</sup>.

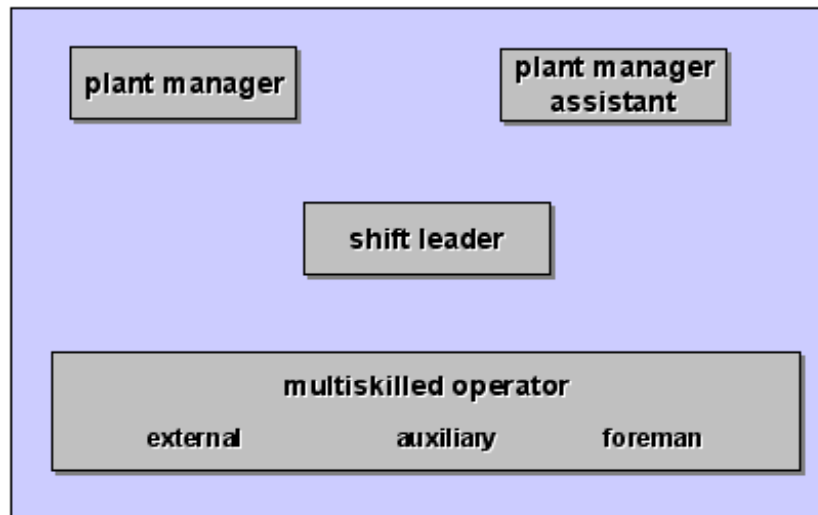

**Figure 19** Each Pilot Plant is operated by teams that are made up of four main roles, working in three shifts.

The *plant manager* holds the more complete knowledge of the plant. He is the interface with the researchers with whom he plans plant activities (and stops). He also coordinates and decides the shifts.

The *plant manager assistant* supports the plant manager and mainly replaces him when he is not at the plant.

The *shift leader* coordinates the shift and has the possibility to decide microvariations on the process.

The multiskilled operator<sup>36</sup> can play indifferently three roles:

- foreman (quadrista)
- external operator

---

each plant can have one or more lines of production. Pilots with more than one line activated at the same moment need more team operators.

<sup>35</sup> Multiskilling has been widely deployed in the chemical sector. While twenty years ago among twenty different professional profiles were necessary to operate a plant, at present most of these competencies have been compacted in one multiskilled operator who can play the role of external operator, process driver and process assistant as a function of the needs of the moment.

<sup>36</sup> The same multiskilling holds also for technicians in the Laboratories.

*"With our system of training, a technician learn all the operations (more that 40) that are performed in my Laboratory, so that I can put him in a shift or in another freely, depending on the need of the programmes" (APRC Manager Assistant).*

- auxiliary operator

As a *foreman*, the operator monitors the plant functioning and maintains the process within the specifics given by the researcher and the plant manager. He also keeps track of the results of ongoing plant activities.

As an external, the operator charges the plant with the different materials (e.g. additives). He also operates the valves and pumps that cannot be activated from the internal control room.

As an *auxiliary*, the operator supports the team in case of necessity. In addition, being at the plant during dayshift, he can learn about the different peripheral activities that are performed to run the installation (e. g. contacts with Materials Department, Maintenance, Laboratories, etc.).

## **Cases of Organisational Learning**

Beside the traditional training system (see annex II for a brief overview), the site has adopted some peculiar practices to enforce learning at all levels. Learning, and more generally knowledge sharing is acknowledged as a key element for successful research. In particular, the two aforementioned strategies of adaptive planning and joint development require a very high degree of integration<sup>37</sup> and flexibility among the different activities/divisions entailing a lot of reciprocal knowledge and continuous learning.

Different practices that enforce learning were identified along a number of interviews. Such practices are directly linked with the concept of Organisational Learning as debated in Fischer (Fischer, 2001) and as stated in the OrgLearn criteria (Boreham et al. 2001). Practices are discussed along three chapters:

- sharing and renewing work practices
- defining and updating procedures and manuals
- participation and joint decision

Each case contains a description of the practices themselves and a discussion in terms of the learning outcomes.

---

<sup>37</sup> For example, each Pilot Plant needs a number of daily analysis for its products. Such analysis are performed by the Laboratories. Coordination between the two structures has to be very well planned to avoid overload, delays and fast changes (e.g. in the case of unexpected outputs).

## 4.2 Case 1: Sharing and renewing work practices through mobility and process integration

As previously mentioned, work is carried out in teams that develop their own practices. The different procedures and practices tend, after some time, to become resistant to change and idiosyncratic. This fact is a central concern for a company that claims to be a Learning Organisation, potentially resulting in a lowering of its capacity of innovation. In such a context, to find ways for sharing and renewing work practices is a key factor for Organisational Learning. The site identified *mutual learning through practice* as its key strategy. In the remainder of this chapter, internal mobility, external mobility, and process integration will be discussed as three examples of how such mutual learning takes place.

### Internal mobility (rotation among roles and plants)

A first means for sharing and renewing work practices is internal mobility, which is also a key factor of success for flexibility:

"I need to have the competencies of each team member as homogeneous as possible. This allows me to plan the activities of the different plants as a function of the real needs of the process. I know exactly how many people are needed to conduct a certain process inside a given plant. Once the pattern of activities have been defined, I need to move people from one plant to another and from one position to another. Such mobility is possible only if I have people with enough training and experience" (P&C M).

Rotations are a prerequisite for obtaining flexibility in planning the activities. The more workers rotate, the more they will be able to change position and/or unit as a function of the need of the work process.

"The meeting schedule was about some team organisational problems. Team leaders discussed some ways to improve team skills and proposals were made for moving individuals from one plant to another, in order to improve their experience and knowledge of the work process" (P&C M).

Up to a few years ago, rotations were decided primarily as a function of the needs of the research processes. Recently, the practice has been stabilised in a system (experimental): all workers are asked about their willingness to rotate and a list is made. It is estimated that about the 10% of the total workforce can be rotated per year. Rotations are rewarded with an advancement following the table below.

<b>C1</b>	<b>+25%</b>	<b>+50%</b>	<b>+75%</b>	<b>+100%</b>
<b>D1</b>	<b>+33%</b>	<b>+66%</b>	<b>+100%</b>	
<b>D3</b>	<b>+50%</b>	<b>D1</b>		
<b>E2</b>	<b>D3</b>			
	<b>E2</b>	<b>D3</b>	<b>D1</b>	<b>C1</b>

**Table 7 Reward system for internal mobility. The first column contains the starting profiles, and the last row contains the ending profiles. Two examples: if an employee is C1, once he has played the role of E2 (in the same or in another plant), he gains +25% of wage. Then, if he goes to play the role of D3, he gains a +50% of wage. In case he is an E2 and he can give his availability to play the role of E2 in another plant, then becoming a D3**

In the following, we will discuss three different types of rotation:

- Rotating among roles within the same unit
- Rotating among units of the same department
- Rotating among departments (Laboratories, Plants, etc.) and between divisions (R&D vs. Manufacturing)

#### **Rotating among roles and teams within the same unit**

Figure 20 below shows the possible rotations inside a plant. Multiskilled operators can become shift leaders and the reverse is possible too (the company tends to have more shift leaders than necessary in order to have a 'reserve of competence' at their disposal). The same vertical rotation is also possible between the role of shift leader and the one of plant manager assistant, and, finally between the role of assistant and the one of plant manager.

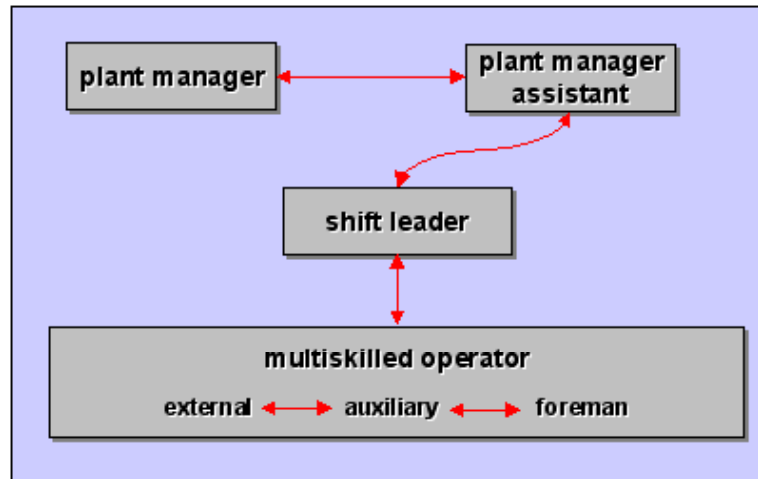

Figure 20 The possible rotations within the Pilot Plant.

### Rotating among units of the same department

Mobility among units<sup>38</sup> can be seen at two different levels: the level of the management (plant manager and assistant, shift leader), and the level of the operators<sup>39</sup>.

At the level of the management, shift leaders are the more likely to be rotated. The plant manager and his assistant are less likely to rotate because they have the knowledge of the plant (and of its history), thus their rotation is less convenient both for the company and for their competence (it would take years to make it up again).

<sup>38</sup> Rotation among Pilot Plants is more likely to happen than other ones because the installations are similar (even if there can be very big differences between one and another).

<sup>39</sup> Even when rotating from one plant to another one, workers start from the position of external operator (see fig. 15).

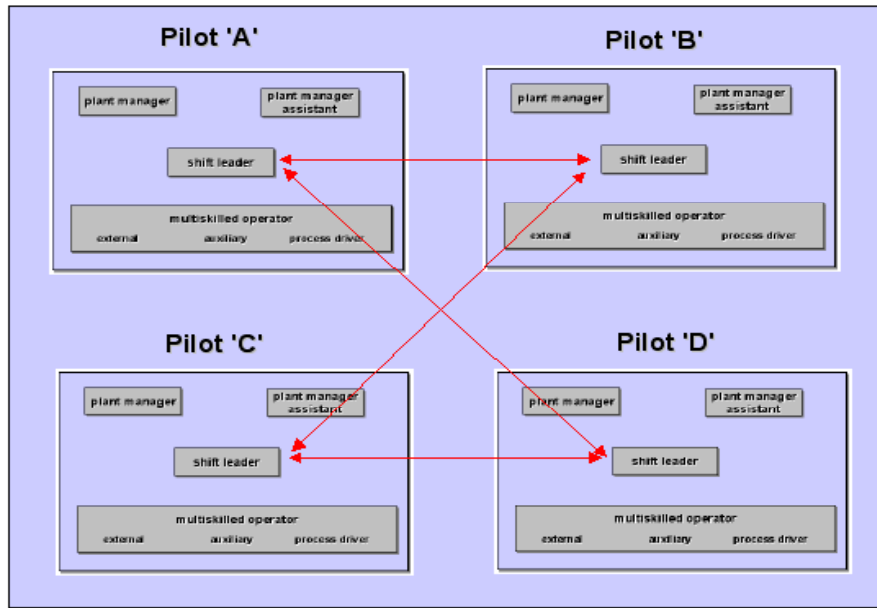

Figure 21 Shift leaders can be rotated quite freely from one plant to another (Details see Figure 19)

At the level of operators, it is very likely that people rotate from one plant to another, as a function of the need of the different programs.

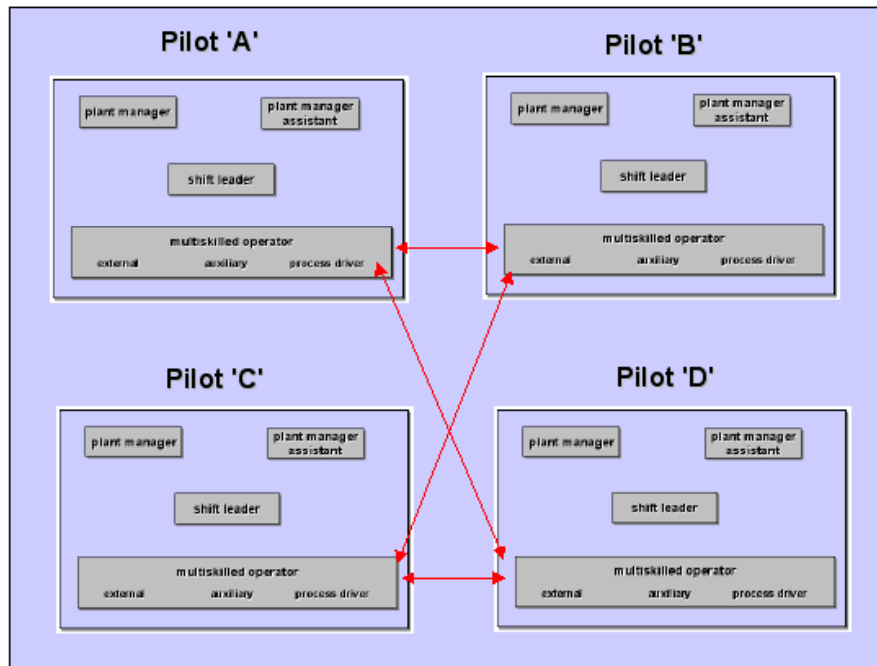

Figure 22 Multiskilled operators, like shift leaders can be rotated quite freely from one plant to another (Details see Figure 19).

### Rotating among departments and between divisions

Rotation among departments and divisions is more constrained than the previous ones. Generally, employees tend to rotate more from and to the Pilot Plants (Figure 23) and rotation is restricted to multiskilled operators<sup>40</sup>

<sup>40</sup> As an exception to this general rule, it was reported along an interview the case of a manager of a Pilot Plant who was transferred in the Services Department with the explicit mission: *'to change department work organisation, aligning it to the flexibility that he experienced for long at the Pilot he was managing. He was appointed to this job both because he had the skills for such change and because he had the deep knowledge on Pilot activity, that are the main clients of the service Department'* (P&C Manager)

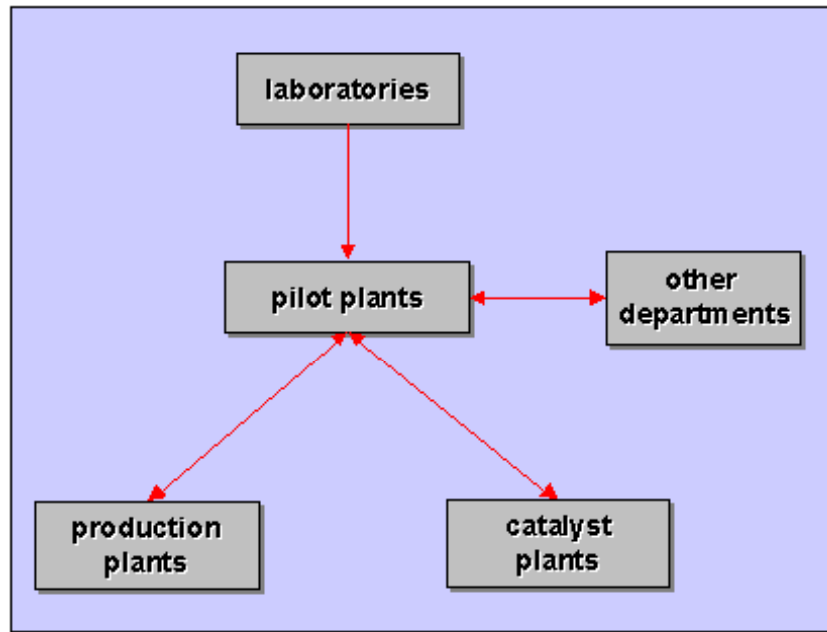

Figure 23 Rotations among departments and divisions are more constrained than previously illustrated ones.

### Consequences for Organisational Learning

Rotating horizontally and vertically among roles, units and plants, results in two main outcomes for Organisational Learning, namely:

- Acquisition of Work Process Knowledge
- Transfer of work practices between communities

Rotating workers is a powerful learning experience that results in Work Process Knowledge acquisition and innovation<sup>41</sup>. In opposition to the Fordist principle for which each worker had to know only what concerned his specific activity, workers acquire knowledge that encompasses more than one's own position/role to cover the different parts of work activity as far as possible (Kruse, 1986; AA. VV. 1999)<sup>42</sup>.

As a second outcome, by rotating, workers let the teams where they are transferred to learn about different practices<sup>43</sup>. For example, when an operator is rotated from unit A to unit B, he carries with him the practices he learnt working in his team at unit A,

<sup>41</sup> Another relevant outcome of rotation is that of contrasting the natural tendency of the different profiles to freeze and create boundaries as time passes.

<sup>42</sup> For additional references to the concept of Work Process Knowledge see also work done within the EU Project Whole - Work Process Knowledge in Organisational and Technological Development (<http://www.education.man.ac.uk/euwhole/about.htm>)

<sup>43</sup> Teams of Pilot Plants represent true communities in the sense of Lave and Wenger (Lave and Wenger, 1993). Each community tend to develop its own work practices.

*"Each team is like a different family. And the way in which work is accomplished and people cooperate depends to a great extent from the shift leader" (P&C M).*

which can differ just slightly, or in certain cases majorly, from the procedures and practices of unit B<sup>44</sup>. By matching the two practices, it is quite frequent that a new way to perform the operations is found and in this way the organisation (or better, the team or/and the unit) has gone through a true process of Organisational Learning. By personal participation at the different activities and teams organisational knowledge is successfully transferred through the different teams.

### **External mobility**

As soon as the chance of hiring temporary workers has been available<sup>45</sup>, the site management recognised in it a way to further improve productivity, having the possibility to activate a number of additional, brief term (temporary workers are hired for a 12 month period) exploratory research programs. To effectively exploit the new opportunity, an entirely new training method was conceived.

Before temporary workers were introduced at the site, to become chemical plant operator two to three years of experience were required. It was therefore quite difficult to imagine how people who would remain in the site for only a one-year period could be usefully employed. Such a difficulty was overcome by both displacing temporary workers to play simple tasks inside well-established processes managed by expert teams<sup>46</sup> and by creating a more effective training process.

The whole process of training is structured along two axis: from theoretical knowledge to Work Process Knowledge acquisition and from a general view on all the main services/divisions to teamwork (see Figure 24).

---

<sup>44</sup> Such a transfer of knowledge and matching of practices can be done, obviously, only for those operations that are similar from one position/unit to another.

<sup>45</sup> In years '96 and '97, for the first time people hired on temporary basis were more than people hired on a permanent one.

<sup>46</sup> At the beginning of their experience in the team, novices become confident with simple tasks because of obvious safety reasons. As soon as they get hands on experience, they are allowed to perform more complex tasks, following a path similar to what is shown in fig. 10.

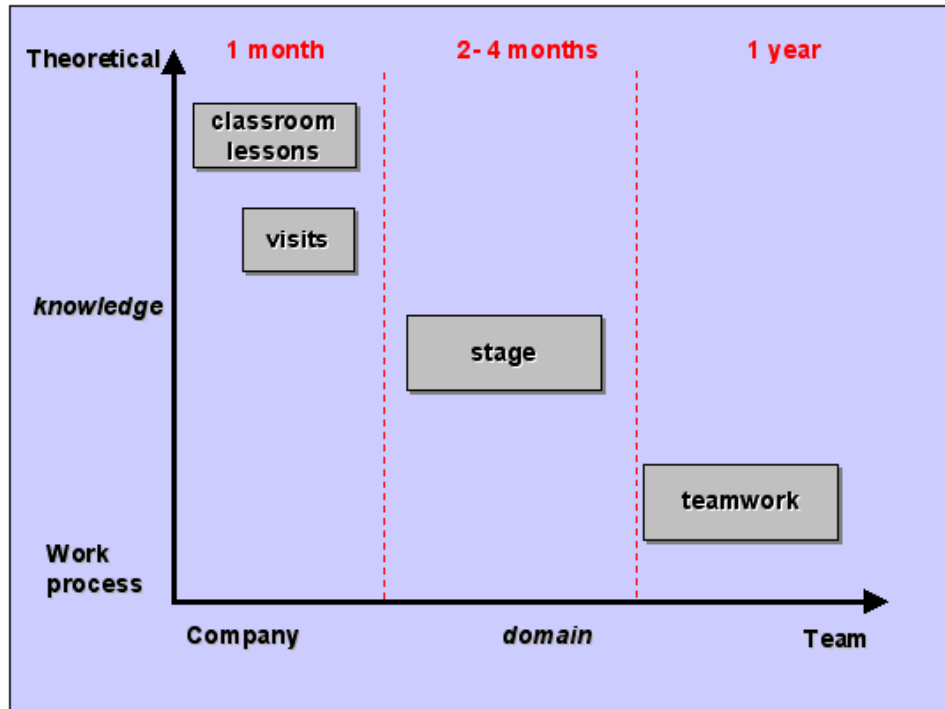

Figure 24 The process of training newcomers.

After having been selected<sup>47</sup>, novices attend a one-month period of instruction tutored by expert technicians working in the centre. The morning is devoted to classes on theoretical subjects, the applications of which will be seen in the afternoon, during some guided tours in the site divisions<sup>48</sup>. If, for example, a lesson is given in the morning about the principle of polymerisation, then in the afternoon there will be a visit to the laboratory where this principle is applied. Independently from the unit in which they will be employed for the one-year contract, along the first month novices are taught, at a general level, about all the different activities that take place along site's divisions (Plants and Laboratories). The first period of class lessons with visits and stage prepares CATs for teamwork in which apprenticeship goes on and learning is fostered by the full participation of newcomers to the team activities<sup>49</sup>.

<sup>47</sup> Novices are selected on the basis of a psycho-attitudinal test, an interview and their educational curriculum. The minimum requirement for attending the selection is the Italian middle school certificate.

<sup>48</sup> While the value of visits and stage was not put into question, the classroom lessons were criticised by one interviewee:

*"Classroom lessons tended to be too much theoretical, and, once on the plant, just a small part of the knowledge was applicable" (CAT).*

<sup>49</sup> The integration of traditional class lessons with apprenticeship within the community of practice (Lave & Wenger, 1991) represented by the team allows a quicker, more thorough socialization of novices (Gustavsson & Ellstrom, 1998)<sup>49</sup>. Teams become "training contexts, setting an example for activities performed and the professional behaviour and orientation required [...] the novice learns how the organisation operates on the basis of cooperation and self-organisation" (Catino and Fasulo, 1998).

When entering teams, novices' learning starts by performing simple task<sup>50</sup> repeatedly. Once a basic skill is acquired, the typical process foresees the learning of another simple task directly linked to the first one (see Figure25).

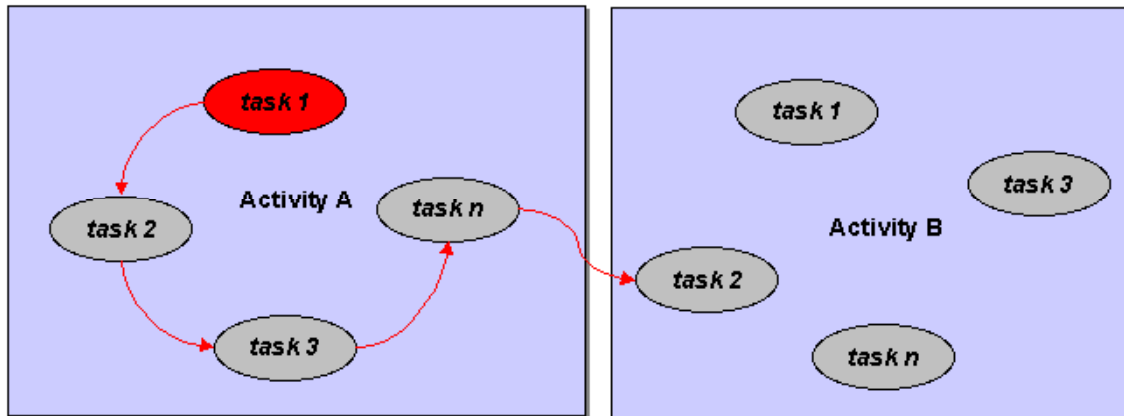

Figure 25 Learning on the job starts from a simple task (or operation) which is performed repeatedly. Then a second task, in proximity to the first one, is learnt and so on, till all the aspects of activity A can be performed with confidence, then the learner changes activity and so on. Such a method allows both flexibility on the company's side<sup>51</sup> and natural creation of meaning on the trainee's side<sup>52</sup>.

Generally speaking, the learning process for a newcomer foresees that everybody starts from the position of external operator, following the scheme in Figure 26.

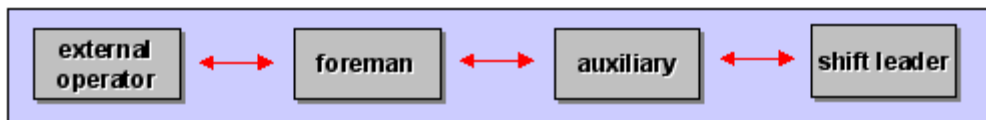

Figure 26 The sequence of positions for learning in Pilot Plants<sup>53</sup>. Workers start from the left (external operator) to finish at the last box on the right. Bi-directional red arrows indicate that employees can come back to the former position if this is needed or requested.

The efficiency of the method can be seen in the evidence that even people without any previous knowledge of the domain (e.g. having a degree in Pedagogy, Humanities or

<sup>50</sup> Task complexity is kept as conservatively simple:

"The tasks we have to carry on are enough simple to be executed with safety and not so simple to get bored" (CAT).

<sup>51</sup> On the company's side such a process has the great advantage that the starting point for a trainee (i.e. the first basic operations) is not fixed, but can be defined with a certain degree of freedom as a function of the needs of the moment (type of operations to be performed at the moment and skilled workers at disposal).

<sup>52</sup> Training recalls two basic principles of learning stated by Vygotskij (Vygotskij, 1978):

i) Knowledge acquired by proximal development;  
ii) Full cognitive development requires social interaction.

<sup>53</sup> Within the site it is quite normal that even engineers and researchers spend their initial training inside Pilot Plants rotating as the operators do, in order to get hands-on experience of the details of the process they will further on design.

Philosophy), after the training period, become full title members of the operational teams.

### **Consequences for Organisational Learning**

Beside the opportunity to further improve productivity, the introduction of temporary workers has relevant learning outcomes. The most important of these being the fact that the initiative, like rotations, was found to be very effective as a means to promote knowledge renewal. Within a company that can have a maximum turnover of 2% workers per year, the opportunity of introducing temporary workers represented an effective chance for experienced workers' to refresh well established work practices and skills<sup>54</sup>.

"Having always to teach to others improves our skills. If we would have not to teach some of our plant's schemes to newcomers, we would not have a look at those schemes for months. In this way, we have to continuously refresh our knowledge" (Team Operator).

"From CAT we learn a lot because, coming from outside, they look at things from a different perspectives, asking unusual questions. They also force us to challenge consolidated assumption *especially when they come from disciplines not directly linked with chemistry*"<sup>55</sup> (Laboratory Research Manager)

A second outcome that can be reported is that, teaching newcomers, skilled workers have to explicitate their experience, transforming procedural into conceptual knowledge<sup>56</sup>.

Finally, the introduction of CATs represent an important trial on the way to link formal education and training with real work experience. The value of such a trial will be improved as soon as temporary work is formally recognized as an educational credit<sup>57</sup>.

---

<sup>54</sup> At the end of their experience, temporary workers are asked to write a short dissertation on some aspects of plant's functioning. Experienced workers help them in writing the dissertation and this is another moment in which they have a chance to refresh conceptual knowledge.

<sup>55</sup> However, the practice is not free from controversial aspects:  
*"When you have to teach to someone who have no prior knowledge in chemicals, the effort in explaining the whys and hows can become really heavy"* (Team Operator).

<sup>56</sup> Nonaka and Takeuchi (Nonaka and Takeuchi, 1995), drawing on Polanyi's (Polanyi, 1966) work, put forward the idea that (new) concepts are generated in the interplay between tacit and explicit knowledge. "It is a quintessential knowledge-creation process in that tacit knowledge becomes explicit ... When we attempt to conceptualize an image, we express its essence mostly in language. Yet expressions are often inadequate, inconsistent, and insufficient. Such discrepancies and gaps between images and expressions, however, help promote reflection and interaction between individuals" (Nonaka & Takeuchi, 1995)

<sup>57</sup> As Lorenz (Lorenz 2000) claims: "... training systems should evolve in ways that provide opportunities for the certification of skills and competencies acquired on the job, and that such certification should translate into chances for promotion and rewards"

### Process integration

Beside job rotation and temporary workers, the site has a third practice to share and improve work practices, that is the continuous<sup>58</sup> integration between activities. In this paragraph we will give an example of the practice, observed in the Applied Research Laboratory of Polymerisation and Control (ARPC).

The ARPC lab of the site is the biggest in the world, with 18 autoclaves (small reactors), about 10 of which are active in each shift. It is devoted to polytest, that is to the process of obtaining polymers by a chemical reaction between a monomer (coming from another site) and a catalyst (made by titanium and magnesium chlorure)<sup>59</sup>. Polytest are performed for different scopes:

- research, both for new products and for the development of existing ones
- quality controls for production plants
- analysis for Pilot Plants
- others (seVICES for licensee plants, etc.)

The ARPC lab employs about 54 workers in 3 teams of 13 people that resemble the structure of teams in Pilot Plants:

- Plant Manager
- Plant manager assistant
- Shift leader
- Technicians (5 in each shift)

Recently, the retirement of one key person (planner) has led to restructure the work process in a way that greatly increased flexibility and integration through a learning experience.

Prior to the loss of the employee, research was carried out as a three actors process: a programme started from an idea given by a researcher, then, in order to test the idea, the planner defined a method that had to be performed by the technicians of the laboratory.

The division had many researchers and technicians, while the planner, who was formerly a researcher, was the only person who was able to write the 'recipes' (non standard, innovative) for the test. Such a situation created a quite rigid workflow that caused delays and inefficiencies. As soon as the planner retired, the management didn't

---

<sup>58</sup> Such integration is continuous in the sense that it is a primary management concern and that it is followed every time that a chance is at disposal.

<sup>59</sup> Exemplifying, monomers can be regarded as flour, catalysts as gist, reactors as the oven, and polymers as the bread, the final product.

replace him, deciding both to introduce a new software system, called 'ASPEN', for complex chemical-physical calculation that could support planning, and to train scientists and operatives together (8 persons each session) in four courses<sup>60</sup> of 60-70 hours each. Training was conceived to acquire technical competencies on ASPEN itself, but also for the two major actors of the work process (i.e. researchers and technicians) to get together on a common ground, so as to learn each other's practices<sup>61</sup>. Such an approach led to a mutual (researchers and technicians) learning process that was successful in understanding each other needs and languages.

"As a consequence, the planning function was successfully abolished. In such way we succeeded in enhancing the degree of system's flexibility: now there are two groups who cooperate in planning, without any dedicated role" (P&C M).

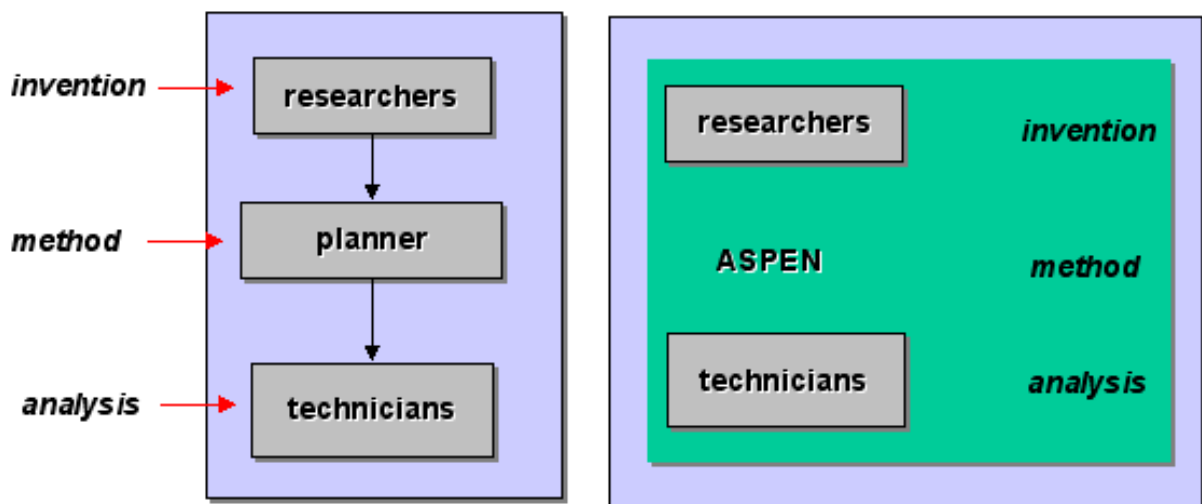

Figure 27 The old and the new work process in autoclaves. Before the new software system was introduced, the different phases of invention, planning (method), and analysis were segmented and attributed to different professionals. The introduction of the new system, instead of a simple way of replacing the planner, was taken as a learning opportunity for researchers and technicians.

### Consequences for Organisational Learning

The planner who left had both the knowledge of the tools (reactors) and methods of the laboratory and the skills of the researchers who provide the ideas. Thus, it was relatively easy for him to provide the recipe. However, he was a unique key professional. Researchers and technicians never had the chance to learn his job: the three roles were

<sup>60</sup> Each course was partly a repetition and partly evolution of the previous one. At the end of each session, in fact, learners were asked to give suggestions for improvement.

<sup>61</sup> The course was only partially focused on the Aspen system. The lessons were also about the basics techniques that are necessary for the process. In a follow-up, trainees express the need for three main classes, that will be held in the next period: a class dedicated to study in detail system's functioning, and two more classes on statistics and instruments.

separated by boundaries of role and knowledge. After the training, a number of learning outcomes have been obtained:

- researchers are able to provide ideas that are closer to the tools constraints
- technicians are able to interpret researchers ideas
- there are no more bottlenecks, and activity and knowledge are distributed in the system, that is much more flexible
- the plant manager can distribute activities in more varied ways
- the division has raised its skills and culture

The multiskilled operator<sup>62</sup> can play indifferently three roles:

### **4.3 Case 2: Defining and updating procedures and manuals from the bottom-up**

Organisational routines stored in procedures tend to be conservative and resistant to change. Two instances are herewith discussed:

- procedures in the ARPC Laboratory
- manuals in Pilot Plants

#### **Defining and updating procedures in the ARPC**

In the last years more and more procedures that were formerly written by the Plant Manager and his assistant are written by technicians. This change happened for three main reasons:

- the venue of quality and environmental systems (the site is certified for ISO 9001 and ISO 14001), that increased the total volume of procedures
- automation that brought an increase in tools complexity and a faster pace of innovation
- the introduction of temporary workers that lend to an increase in procedures that were not previously written because they were part of skilled workers' competence<sup>63</sup>.

---

<sup>62</sup> While twenty years ago twenty different professional profiles were necessary to operate a plant. The same multiskilling holds also for technicians in the Laboratories.

"With our system of education, a technician learn all the operations (more that 40) that are performed in my Laboratory, so that I can put him in a shift or in another freely, depending on the need of the programmes" (..)

Actually, the Plant Manager no longer has the specific knowledge that is necessary to write a procedure.

"Only the one who has common practice with a certain operation holds the knowledge to write it [...] More people contribute to the drafting of procedures so that I'm more confident that the final one is not the product of a single, even if highly skilled, individual, but resides on the competence of different contributors" (APRC Manager Assistant).

Procedures are drafted by technicians and issued by the Plant Manager who still holds the formal responsibility for the final editing.

"Whenever a new operational procedure has to be formalised, I ask to the people who would use it to produce a draft. Then, I personally revise it and discuss some minor changes. After the changes have been discussed and accepted, the procedure becomes officially approved" (APRC Manager Assistant).

### **Consequences for Organisational Learning**

The outcomes in terms of Organisational Learning are quite obvious here. The participation of technicians to the definition and update of the procedures represent a clear instance of the process of transfer of knowledge from the individual to the organisational level.

### **Defining and updating plant manuals**

Plant manuals are stored in the local computer network and can be consulted in paper documents which are available at each plant. Manuals describe the main components of the plant at different levels (mechanical, electrical, etc.) and their functioning. Each Plant has a manual with the schemes and the procedures on how to operate it. Manuals have to be updated quite frequently because of the continuous innovation that takes place at the technological level and because of the continuous changes in the programs (see Figure 18).

Often, changes on the plant are suggested by operators and drafted by the plant workers.

"Changes are not designed directly by engineers because they tend to make these too complex. We end up with better and simpler changes by conceiving modifications by ourselves, internally" (Pilot Plant Manager).

---

<sup>63</sup> CATs, in fact, rely on written documents as additional sources for their apprenticeship.

*"With the introduction of CATs we discovered that one procedure was written at a general level, without specifying how to behave in certain, low frequent but dangerous conditions" (APRC Manager Assistant).*

After a modification has been drafted, it is passed to engineers who make a further draft to be revised. The final design with comments by plant personnel is given again to engineers who complete the details and finally implement it.

"We recently had to feed the plant with a new component for which we discovered to need a special tank. Such tank was drafted by us and then passed to engineers for the final project" (Pilot Plant Manager).

The changes are then written in the plant manual by the Plant manager and communicated through the shifts.

### **Consequences for Organisational Learning**

As for the case of procedures in the ARPC laboratory, the outcomes in terms of Organisational Learning comes quite straightforward. In the Pilot Plant, however, updates and suggestions are put forward more at a team level than at an individual level. Plants, in fact, are more collective structures than Laboratories. As a consequence, for any change or update, a lot of discussions take place with all teams involved, which means that the Plant Manager has to run at least one meeting for each shift to both take the decision and to communicate and receive feedback on it.

#### **4.4 Case 3: Participation and joint decision: a structured meeting system**

Beside renewing work practices, procedures and manuals, an essential element related to Organisational Learning is participation that allows joint decision. The site has adopted a particularly rich and structured system of meetings. It is along the different types of meetings that a lot of decisions affecting activities and programs are taken and it is along these meetings that workers can inform and influence the initiatives that are taken for organisational change.

In the last twenty years, the site has always been characterised by a high degree of participation and intensive union-management joint decision processes. The main reason for this fact resides in the very high technical qualification of the union delegates. Delegates, in fact, are often high skilled operators who know very well the different aspects of the work process, and their opinions and comments are highly valued by the management.

Participation is guaranteed by six different types of meeting (see tab. 9).

Meeting type	Participants	Purpose	Periodicity
Shift meeting	Shift members	Exchange info from one shift to the next	every shift
Team meeting	Team members	Exchange info relevant for the plant/site	monthly
Work meeting	Workers of teams/units/deprtment/divisions	Tracking and planning of programmes	2/3 per year
Operative meeting	Responsible of teams/units/departments/divisions, technical line, Union delegate	To solve medium - small technical and professional problems	2/3 per year
Technical meeting	Area Unions delegates & technical line	To solve major technical and professional problems	1 per year
Joint committee	Unions delegates & technical line	Rewards, human resources management, near misses analysis, education, etc.	when needed
Company bargaining	Unions delegates & top managers	Rewards	when needed
Unions assembly	Unions members & Unions delegates	Prepare for company bargaining	when needed

**Table 8 The six types of formal mechanisms for participation and knowledge sharing.**

The different meetings can be represented at two levels: a macro level (decision on policies) and a micro level (decisions on activities). At the macro level there are the Joint Committees, Company Bargaining meetings and Unions Assembly. Joint Committees are constituted to solve problems that concern the site as a whole. Company Bargaining concerns the site top managers and Unions delegates and is the place where new norms or interpretations can be introduced and personnel allocation is defined. Finally, Unions Assembly takes place at all the different levels (teams, areas, and divisions), involving both workers and Unions delegates.

"Technical meetings are essential to clarify the evolution of the programmes and reciprocal commitments [...] to locate in a global vision the variability and the interdependence within the different work processes" (P&C M).

### **Consequences for Organisational Learning**

The system of meetings can be referred to as a permanent practice of Organisational Learning.

Meetings, in fact, allow the continuous update of all the workforce on:

- Work programs
- Technical innovations
- Procedural innovations
- Organisational changes

On overall, it can be said that meetings:

"are an instrument for information [...] taking on a fundamental role in integration and involvement of the various skills [...] they ensure that information circulate more rapidly [...] it is in these meetings that updates are

given on the work schedules, on the technical innovations to be achieved, and on the work organisation" (excerpt from a Union-Corporate agreement dated back in 1995).

## 4.5 Conclusions

The research division of the chemical company of the study has a long tradition in "systemic reflection and change in the culture" (Fischer, 2001) that lies at the basis of the concept of Learning Organisation. Through the years, the division has developed some unique key features that contributed a lot to maintain its leadership in the world. Joint development of product, technologies and processes, adaptive planning, and teamwork equally represent advanced strategies that resulted in a very flexible and effective organisation. The fulfilment of these strategies depend a lot on the extent to which:

- members of the organisation are able to learn from each other and from the different communities of practices
- procedures and, more in general, organisational memories, are renewed and updated
- information is exchanged and decisions are taken in a participatory way

All these elements are obtained through practices that can be referred properly as practices for Organisational Learning. It can be objected, however, that the previously described practices are not systematic in the sense that there are no standard procedures, e.g., that allow people to match their different work routines. Such a fact is due to: i) the evolutionary nature of the learning practices that take place on site; ii) the nature of the research process; iii) to company's worldleading position. The practices of Organisational Learning at the site are *evolutionary* in the sense that they didn't come as a consequence of recent management principles and methods but they were internally conceived and developed in a continuous way. Such practices began to be developed around the end of the seventies, primarily as a way to come out from both a period of crisis for the chemical industry and from a straining conflict in industrial relations.

*Research processes*, then, are difficult to be standardised and tend not to be based on routines, it is therefore quite difficult to have e.g. 'best practices' to settle.

Finally, it has to be noticed that the site is *world leader* in its research domain, and consequently it is at the forefront of innovation, what makes it difficult for the company to systematically learn from others<sup>64</sup>.

The different cases that have been discussed along the report matches to a different extent the whole set of criteria of Organisational Learning. In the following we highlight the most relevant matches for each criterium.

### **Criterion 1. Organisational work routines are being evaluated and improved**

Work routines are evaluated and improved both at an organisational level, in terms of changes in teams and programmes, and at the level of activities, as it has been reported along paragraph ‘internal mobility’. Also paragraph ‘external mobility’ deals with this criterium.

### **Criterion 2. Formal and informal learning processes are being evaluated and improved**

The case of training newcomers and CATs, discussed along paragraph ‘external mobility’ matches this criterium. Also ‘process integration’ is relevant for the topic.

### **Criterion 3. Transformations are occurring in the culture of the organisation**

Internal culture changed a lot in the last twenty years. Unions are less conflictual and more cooperative with the site management. It is their alliance that allowed the big innovation in work organisation that has been described along the report. A strong effort has been done in enforcing participation and some examples can be seen in par. ‘participation and joint decision’. Teamwork has almost completely taken the place of hierarchy and the number of layers has been lowered to a great extent.

### **Criterion 4. Knowledge is being created within the organisation, at different levels (not only by the managers/scientists) and it is being shared within the organisation**

Instances of this proposition have been described throughout all the paragraphs, with paragraph ‘defining and updating procedures and manuals’ particularly focused on this topic.

---

<sup>64</sup> As a last note on the non systematical nature of the practices, the position of E. Wenger (Wenger, 1998) can be reported: “... if we believe that people in organisations contribute to organisational goals by participating inventively in practices that can never be fully captured by institutionalised processes, then, we will minimise prescription, suspecting that too much of it discourages the very inventiveness that makes practices effective.”

**Criterion 5. Learning from the environment is encouraged and systematically evaluated. The results are assimilated and accommodated to the company's objectives and local constraints and opportunities**

The site is world leader in its research domain. It is therefore more likely that other companies visit the site to learn from their experience than the reverse. The more relevant exchanges with the external environment (exchanges with University) have been discussed in Annex I.

**Annex I – VET and Educational initiatives with external bodies**

In Italy to become a chemical plant operator there are not real VET courses. Candidates normally come out from technical schools and then learn on the job. Because of this, it is quite difficult to discuss about the relations with the VET system. However, the site of the investigation has autonomously built a series of links with institutions providing higher education, mainly the local University. Figure 28 shows the bi-directional relations between the site and the University, which represents the most important external educational body for the site.

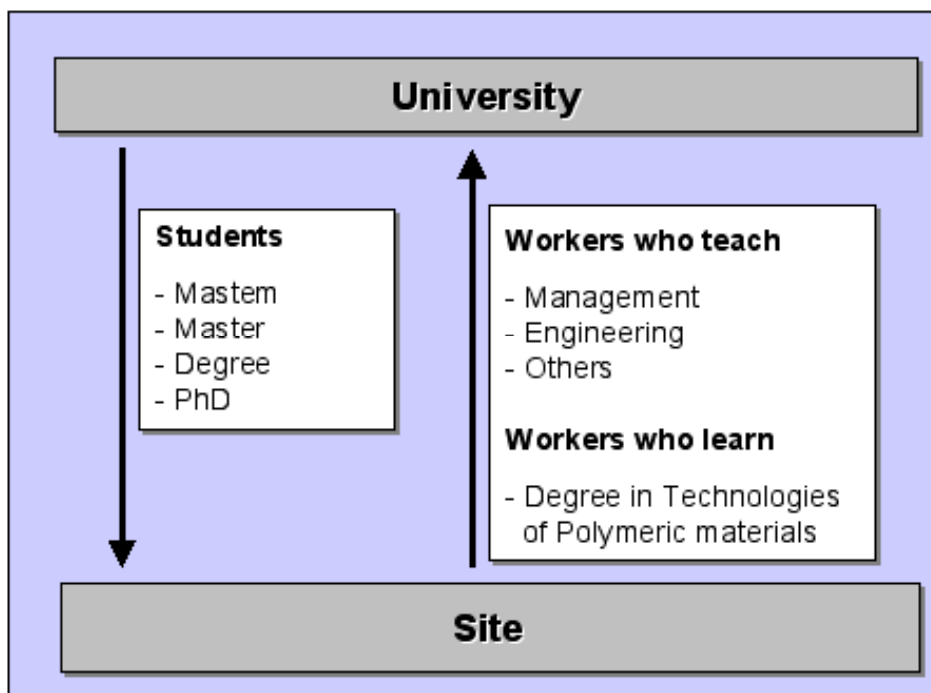

Figure 28 Exchanges between the site and the University.

**Annex II - The formal training system**

The responsibility of identifying learning needs is formally given to the line manager. The line manager and his assistant identify learning needs with respect to:

- Established tasks and goals
- Career path
- Job description
- Professional Development Model (PDM)

Training needs are also raised by the line manager each time that either a change of position or a long period of absence are foreseen. Other requests for training might normally come from Health, Safety and Environment function (HSE) and the Quality Manager (QM), who call for specific lessons on environmental, safety and quality issues.

Once learning needs have been defined<sup>65</sup>, a request is sent to the Human Resources (HR) manager.

**Figure 29 the general training process**

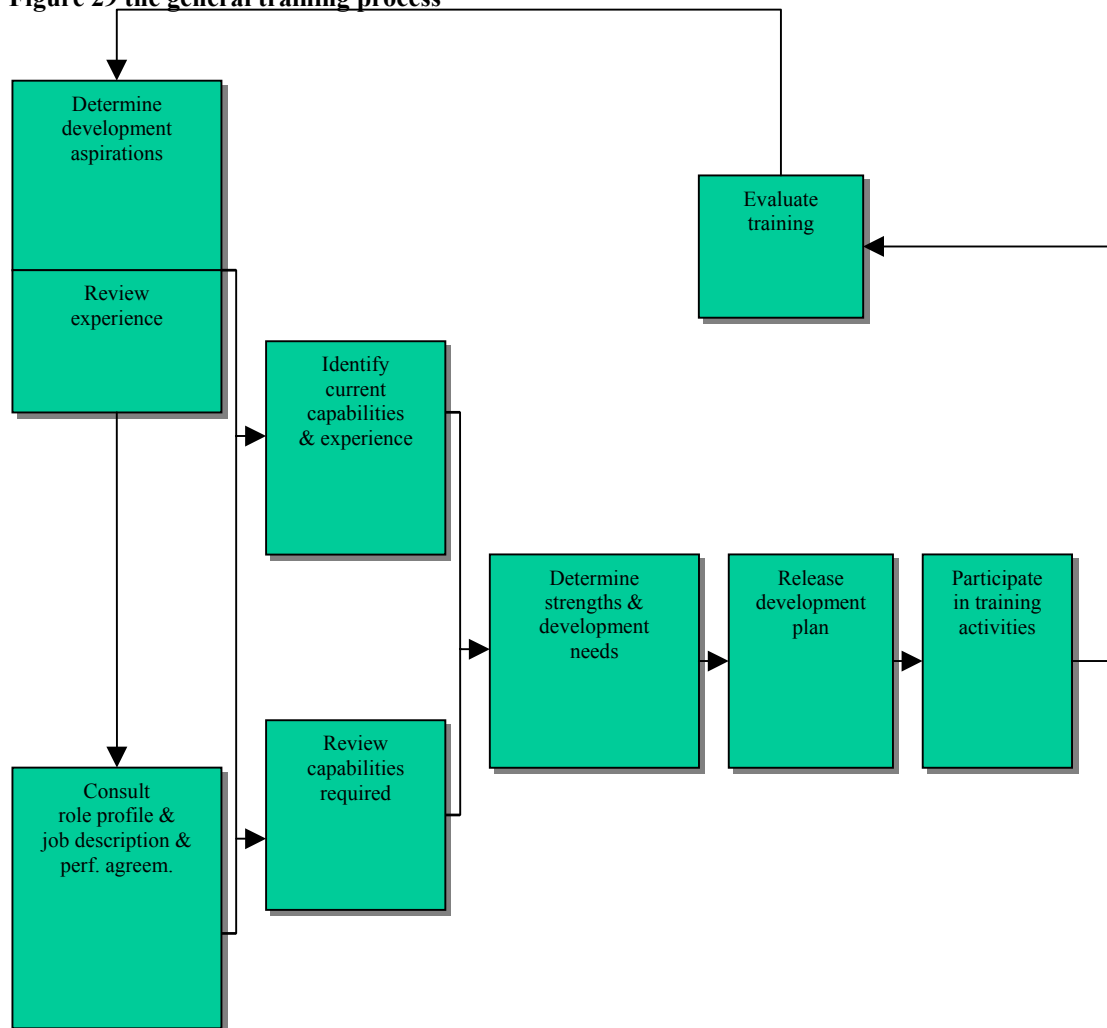

<sup>65</sup> For what attain to the management, learning needs are also assessed within the general scheme of Individual Performance Management (IPM)

Once training needs have been collected, then HR:

- Verifies the coherency of the different requests
- Makes an economical estimation of the effort to be invested
- Compile the Annual Plan of Training (APT)<sup>66</sup>.

The scheduling of training is reported within the function or division Annual Improvement Plan (AIP).

In the near future, the whole set of training opportunities will be available to everybody through the Intranet, making it possible to directly subscribe to the course of interest and to personally track and build one's own development process.

Training contents are distinguished in three main typologies:

- Core functional
- Core managerial
- Basic (IT, languages, quality, safety, etc.)

The majority of courses are devoted to the acquisition of technical competencies targeted to promote innovation in the work process and improve system's flexibility.

The effectiveness of training initiatives is assessed directly by the attendees at the end of each course by means of a nine items questionnaire requiring an evaluation of both the contents and the management of lessons (e.g. "To what extent have your expectations been met?"; "How well was the training organised?"). Three months later both the participant and his responsible evaluate through a three items questionnaire the effectiveness of the course with a particular focus on the improvement of knowledge and competencies related to the specific job carried on (e.g. "How would you rate the overall effect of the course on your job performance?"). Each year non managerial personnel will report within the PDM form the different courses that have been attended in the twelve months and annotate the achieved results. HR collects all the information and, at the end of the period foreseen by the APT, reports to the site management.

---

<sup>66</sup> It is always possible to set up new training activities along the year that were not planned in the APT, given that the budget is available.

## Acronyms

<b>AIP</b>	<b>Annual Improvement Plan</b>
<b>APO</b>	<b>Advanced Polyolefins</b>
<b>APT</b>	<b>Annual Plan of Training</b>
<b>ARPC</b>	<b>Applied Research Polymerisation and Control</b>
<b>BAPP</b>	<b>Behaviour Accident Prevention Programme</b>
<b>CAD</b>	<b>Computer Aided Design</b>
<b>CAE</b>	<b>Computer Aided Engineering</b>
<b>CAT</b>	<b>Temporary Worker</b>
<b>CER</b>	<b>Ferrara Research Centre</b>
<b>HR</b>	<b>Human Resources</b>
<b>HSE</b>	<b>Health Safety and Environment</b>
<b>ICT</b>	<b>Information and Communication Technologies</b>
<b>IT</b>	<b>Information Technology</b>
<b>IPM</b>	<b>Individual Performance Management</b>
<b>IG</b>	<b>Society for Young Entrepreneurship</b>
<b>ISO</b>	<b>International Standard Organisation</b>
<b>IT</b>	<b>Information Technologies</b>
<b>LO</b>	<b>Learning Organisation</b>
<b>OD</b>	<b>Organisational Development</b>
<b>OL</b>	<b>Organisational Learning</b>
<b>P&amp;C M</b>	<b>Planning and Control Manager</b>
<b>PDM</b>	<b>Professional Development Model</b>
<b>PE</b>	<b>Polyethylene</b>
<b>PP</b>	<b>Polypropylene</b>
<b>QM</b>	<b>Quality Manager</b>
<b>RCP</b>	<b>Responsible Care System</b>
<b>VET</b>	<b>Vocational Education and Training</b>
<b>WPK</b>	<b>Work Process Knowledge</b>

## References

- AA. VV. (1999). Whole Final Report. Deliverable for the EU Commission.
- Kruse W. (1986). On the necessity of labour process knowledge. In: Schweitzer J. (ed.) Training for a human future. Weinheim, Basle.
- Bordogna L. (1989). Il caso del petrolchimico Montedison di Ferrara. In Regini M. and Sabel C. (Eds.): Strategie di riaggiustamento industriale. Bologna, Il Mulino.
- Boreham N., Fischer M., Huys R., Mariani M., Morgan C., Parlangei O., Röben P., Van Ruyseveldt J. (2001). Criteria for Organisational Learning. In M. Fischer and P. Röben (Eds.): Ways of Organisational Learning in the Chemical Industry and their Impact on Vocational Education and Training. A Literature Review. Insitute of Technology and Education, University of Bremen.
- Catino M., Fasulo A. M. (1998). Organisation for innovation. A case study in 'G. Natta' Montell Research Centre in Ferrara. Milano, Angeli.

- Fischer M. (2001). How to conceptualise and investigate Organisational Learning in the Learning Company? In M. Fischer and P. Röben (Eds.): *Ways of Organisational Learning in the Chemical Industry and their Impact on Vocational Education and Training. A Literature Review*. Insitute of Technology and Education, University of Bremen.
- Gandini A., Foschi G., Flammini R. (1999). *Apprendere lavorando. Programmi formativi e inserimento dei giovani nelle imprese*. Reggio Emilia, Diabasis.
- Gustavsson M., Ellström P. (1998). Exploring the potentials for work-based learning in process operator work. Documentation of the second Whole Workshop, Siena, 2-4 December.
- Lave J., Wenger E. (1993). *Situated learning. Legitimate Peripheral Participation*. Cambridge University Press, NY.
- Nonaka I., Takeuchi H. (1995). *The knowledge-creating company*. Oxford, Oxford university Press.
- Polanyi M. (1966). *The tacit dimension*. Routledge and Keegan Paul, London.
- Wenger E. (1998). *Communities of Practice. Learning, Meaning, and Identity*. Cambridge University Press, NY.
- Vygotsky, L.S. (1978). *Mind in Society*. Cambridge, MA: Harvard University Press.

---

*Nicholas Boreham and Colin Morgan*

## **5 Cases of Organisational Learning in company U (United Kingdom)**

### **5.1 Company U's approach to Organisational Learning**

#### **Company Background**

Company U is part of an international group of petrochemical companies which is one of the largest industrial undertakings in the world. The UK site involved in the ORGLEARN studies refines, manufactures and markets products from crude oil. Some of these are sold directly to the consumer, but the majority are sold to other chemical companies, which process them further. They are then used in virtually all kinds of manufactured product.

In outline, the production process at Company U is as follows. Crude oil arrives on the site and is placed in the company's feed tanks. Each batch is subjected to detailed chemical analysis before it enters the refining process, to establish the best use the company can make of it. It then goes into the distillation plant, which separates it into propane, butane, tops, naphtha, kerosene, gas oil, waxy distillate and long residue. These substances are then fed into up to 10 more plants, each of which is operated by a separate team. The processes in these plants effect changes such as altering molecular structure, removing unwanted substances such as sulphur, further separation of substances, and so on, depending on what is being produced. The plant are organised into two main groups. The first comprises platformers, a merox treater, a hydrogen sulphuriser, an aromatics production unit and a base lubricant oil plant. The second group includes a catalytic cracker, an ethyl benzene unit and an alkylation plant. Energy produced by the catalytic cracker runs an electricity generation plant, which supplies the site and can export electricity as an additional product.

In common with other oil refineries, Company U has faced major challenges over the last few decades. In the 1960s, oil refining was a successful and relatively straightforward business. There was rising demand for its products and little international competition, and profit margins were substantial. Consequently, the reliability of the production process was

not as critical to the success of the business as it later became. Since the rise in the price of crude oil in 1974, the business environment has changed significantly. The economic recessions of the early 1980s and 1990s were profound shocks for the chemical industry, creating many problems including a reduction in investment. Today, there is falling demand for chemical products, a worldwide over-capacity in production and strong competition from new chemical industries established in the Pacific Rim. It is clear to everybody in the business that in order to survive, Company U needs to improve its performance continuously.

### **Company reorganisation**

In response to falling profit margins and the pressure of competition, over the last few years Company U has made significant changes in its business process. In this section, we will concentrate on the organisational changes that provide a context for the company's emphasis on organisational learning. Since 1991, the company has downsized from 1800 employees to the present payroll of 850, partly by increasing automation and partly by outsourcing non-core activities such as buildings maintenance. In earlier days, the company was organised predominantly around technical functions, but today there has been a shift towards multi-functional units that are run as businesses and are more customer-oriented. There has been a significant amount of delayering, principally the removal of supervisory grades. This has reduced the hierarchy in a typical plant in the oils division from seven levels to just three or four. There has also been a reduction in horizontal demarcations. Multi- and cross-skilling has been introduced: previously there used to be more than ten craft trades, now there are just two. Although this reduction is partly due to outsourcing, it nevertheless represents a significant increase in functional flexibility. About 15% of plant maintenance is done by process operators, who have been trained in first-line maintenance, and mechanical and electrical/instrument technicians can all do a bit of each other's trades. The benefit is not primarily that fewer employees are required overall, but that jobs can be completed more quickly and internal communications are improved.

A very significant change has been the move towards teamwork as the basis for most operations. Previously, it was normal for routine tasks to be carried out by individual employees. Thus a process operator would come into work, find out from the foreman what specific task he had to do and proceed to do it on his own, with few of his co-workers being aware of what he was doing. This of course meant that they did not share in any lessons that might be learnt. The elimination of the grade of Charge Hand was crucial in the move towards more reliance on teamwork. Charge hands were very experienced workers who would tend to take the lead in most tasks (one interviewee described them as

"still having their gloves on"). They would assign tasks to operators on an individual basis, a method which tends to restrict communication to a private dialogue between the charge hand and the worker concerned. There has also been a change in the role of Shift Team Leaders, who now 'helicopter' over several plant instead of providing close and constant supervision in one. With the end of direct supervision, the operators in a plant now have to assume more responsibility and work as a team, making decisions collectively that previously were handed down to individuals from above.

Company U has witnessed a significant culture change over the last few years. Without doubt, there is much more sharing of information, and a spirit of co-operation is dissolving barriers between departments that previously held themselves apart. A major attempt has been made to improve internal communication by regular site conferences, and a new management style has been encouraged which encourages two-way communication. All employees are linked through an intranet and there are now many more meetings involving all levels of employee to discuss the work process.

We will now discuss the new emphasis on learning which has accompanied these developments. The company has introduced a five-year site plan which is issued to all employees and provides a reference point for everybody's work. The mission statement in this booklet stresses that *learning as an organisation* is one of the core values that will help the company become the best refinery in Europe. The mission statement emphasises the need to *learn as a company from past mistakes and successes*, and to *openly share knowledge and learning within the company*. All levels of employee are expected to know the contents of the site plan. In the remainder of this chapter, we will discuss three specific initiatives taken by Company U to promote organisational learning.

## **5.2 Case 1: The Systematic Approach**

The first case is a major initiative that started six years ago. The aim was to encourage staff to work independently in teams to solve problems encountered in the workplace, and to learn from the process. An external training provider was engaged to put on a course in team working skills for all employees. Emphasising 'soft' skills such as listening and group problem solving, the course promoted a stages model of problem solving known as the Systematic Approach. This involves forming a problem-solving group to decide on and implement action whenever a complex instruction has to be carried out (e.g. preparing for an audit inspection), when a problem is identified (e.g. a recurrent fault in a piece of equipment) or when an incident occurs (e.g. a complaint from a contractor). The Systematic Approach can be initiated anyone, process operators as well as management. The initiator will convene a meeting of all the employees who are affected by the task or problem. The group then tackles the problem collectively by following the steps prescribed

by the Systematic Approach. These are: defining the purpose of the exercise by setting goals and agreeing success criteria, allocating sub-tasks to individuals (typically, gathering the information needed to solve the problem), taking action (such as devising a new procedure), then reviewing the degree of success achieved.

All employees were trained in the Systematic Approach. At the end of their training courses, they were formed into small teams and given "back at work" tasks which they carried out in the workplace using the Systematic Approach. Mostly, these were problems identified by management, although some were suggested by the teams themselves. A typical example was to find a way of reducing the level of waste in one of the production processes. Later the teams reported back at a series of meetings which were overwhelmingly supportive of this new way of working.

An example of the use of the Systematic Approach can be given as follows. A contractor (an outside firm building new plant on the site) reported difficulties in obtaining materials from the company stores. The construction co-ordinator, who received the complaint, convened a Systematic Approach group which included members of the departments involved (stores and procurement), the contractor himself and the contract manager. After agreeing the aim of the meeting and the success criteria, the participants were tasked to gather relevant information. When the procurement department and the company stores reported on their procedures for supplying material, it emerged that refinery employees were given preference over contractors and this was the root cause of the problem. Up to that point, none of the departments involved had realised that the procedure was causing difficulties for outside firms. So the Systematic Approach group recommended an appointment system which would give contractors two set times each day when they could obtain the material needed for their work. The stores and procurement department amended their procedures accordingly, and future problems of this kind were avoided. All this was done without any involvement of management.

The Systematic Approach is now part of everyday working practice at Company U. Almost all respondents stressed that it has become part of the company culture. Many of the employees who were interviewed said that they had internalised this process: "It's normal business now". When it was introduced, the process operators regarded it as a management activity that was not really intended for them, but according to a company audit 40% of operators and maintenance technicians use it on a regular basis (85% of other staff use it regularly). The involvement of operators and maintenance technicians is seen as critical to the success of the Systematic Approach in bringing about continuous improvement in working practices. As one interviewee commented, "You're much, much more likely to succeed with an initiative that involves them".

The original series of training courses has not been repeated. However, steps have been taken to ensure the maintenance of these skills by engaging the external training provider to train a selected group of employees as facilitators of the Systematic Approach. These staff are now providing internal consultancy in its application in the workplace in addition to doing their regular jobs. If the need is felt, the convenor of a Systematic Approach meeting can call one of the facilitators in to coach the group through the process.

The Systematic Approach promotes organisational learning. It has changed the nature of everyday working by introducing an element of knowledge creation into the work process, and by involving all relevant employees it ensures that the learning occurs on an organisational level. Before the Systematic Approach was introduced, one interviewee explained:

"You'd have a problem, and it would hang around for months and months. And unless you actually had an individual decided to do something about it, pushing and pushing it ... it wouldn't go away. "

Now, however,

"The Systematic Approach has made a lot of people more aware of how you go about getting something done if there's a problem, rather than whinge about it ... You tend do something about it now ... Previously, problems never got solved unless individuals took it upon themselves to pursue it to a level where you got the backing of a lot more people to do something about it. Whereas now people's approach to problems is different. It's done quick, low key and if it's come out with a correct result, people are more open to change their views or the ways than say 10 years ago, when they didn't want to know."

As a result of the Systematic Approach, working practice can be more reflective:

"... by making people think about what they're doing, ... they may highlight things that may go wrong, that could go wrong, that could cause a problem "

### **5.3 Case 2: Procedural and Competence Development Methodology (PCDM)**

The second case of organisational learning in Company U is an initiative called Procedural and Competence Development Methodology (PCDM). The objectives are to identify best practice in operating procedures (such as bringing a new pump on line), write a new set of procedures manuals embodying these procedures and as an integral part of this, promote the sharing of this expertise throughout the workforce. PCDM was introduced by a working party in Company U in order to systematise the confusing mass of safety procedures, which had never previously been co-ordinated. These were set out in numerous booklets which were placed in control rooms and other work sites. The project aimed to replace them by a computer database containing a set of new procedures which

had been reviewed and confirmed as best practice. However, the original initiative was soon extended beyond this in two ways. First, when an external consultancy was brought in, the scope was widened to include knowledge sharing as a specific objective. Secondly, it was extended to include all the operating procedures, not just safety procedures – and indeed, potentially any task carried out in the company.

The most innovatory aspect of PCDM is that the new procedures are written by the operators or other employees who actually carry out the work, not by management or other senior staff. Tasks are selected for PCDM in two main ways. Sometimes a task is put through PCDM in response to a problem. For example, if a £40,000 pump blows up when being brought on-line, it is likely that a PCDM group would be established to work out a procedure for carrying out this task in a more effective way. However, the main way in which tasks are selected for review by PCDM is by applying the company's Risk Assessment Matrix to an inventory of all the work tasks in the company. The tasks judged the most risky are assigned priority for PCDM.

PCDM methodology is highly structured. In essence, the process is to convene a meeting of all the employees whose job includes carrying out the task in question. Typically, this will be the members of the five shifts who perform the task. The five employees are taken off their shifts, or brought in when off-duty and paid overtime, and put in an office to exchange information on how they do the task. Detailed worksheets are provided to help them in this. Having explored the different ways of doing the task, they then have to agree on the best method. This is written up as a set of detailed operating procedures, and the team produces overviews and where necessary job-aids such as wall charts. Next, the new procedures go through an authorization process - typically, this involves a review by a refinery technologist, by the head of operations for the plant and finally by the plant manager. Thus, although new procedures are developed by operators, they are checked for safety etc. by senior employees. After authorization, the new procedures become company policy.

Prior to the introduction of PCDM, most of the standard operating procedures were written by chemical engineers who had never worked as operators. Now it is accepted that standard operating procedures should be written by the employees who use them. As one chemical engineer said,

"I found it strange when I came here that I was writing operating procedures, because I'm not the guy who actually goes and turns the valve back, and say process-wise, this is the best way we should do it. You should get someone who does the job to write it. I like this much better."

Because the standard operating procedures written by chemical engineers were not based on actual practice, they left many questions of detail to be filled in by operators. The result

was that each operator had devised his or her own way of performing a task, some of which might be safer or more effective than others. Consequently, one advantage of PCDM is that it is standardising operating procedures on the basis of agreed best practice. This can only result in an overall improvement in performance at an organisational level. However, PCDM is promoting learning too, on several levels:

*(1) Sharing experiences among the (typically) five operators who carry out the same task on different shifts.*

The setting up of PCDM groups may be regarded as the creation of 'learning cells' within the company, a structure which promotes the sharing of experiences and debate about how to deal with problems. Previously, as already explained, each operator would follow his or her own practice without much opportunity or inclination to share these experiences. As one interviewee said:

"If you went out and did an operation on a column, ... in the old days you wouldn't necessarily tell anyone what you'd done, or how you'd done it, or whatever, unless there was a trainee with you . Where people are more likely to talk now is: 'Hey, I went out and did this, and I followed the procedure, but that's not the way we should be doing it ... And then talking to their mates and saying 'Well, what do *you* think of it?'"

The learning is collective:

"The important aspect of [PCDM] is that it's done by consensus, by the whole of the group that's going to be involved."

According to many interviewees, the participatory nature of PCDM is crucial for ensuring that the new procedures are adopted by the majority of the workforce. Only if a person has taken part in rewriting new procedures is he/she likely to take ownership of them and adopt them willingly. Previously, when procedures were written by managers or technologists, and handed down, operators would resist changes.

"By getting [the operators] to take ownership of everything, it sort of gets into the culture of things, and it's them that are coming up and saying 'This point here, we don't think it's critical any more'" [i.e. operators are volunteering information about the production process that will be helpful to the plant technologist who is responsible for its design].

*(2) Horizontal dialogue in the workplace about best practice.*

In addition to discussing procedures among themselves, the PCDM team also show drafts of their proposed new procedures to colleagues whose work impinges on them. This extends the learning process much more widely.

*(3) Vertical dialogue between management and operators about the best way to carry out operations in a plant.*

Due to the authorization process, knowledge generated by operators is shared vertically up the management hierarchy. An example of this kind of learning is a PCDM project that identified what came to be called 'critical control points'. These were points in the process that affected the quality of the product and were capable of adjustment by operators. Based on this realisation, the PCDM team drew up procedures by which operators could gain better control of the process at those points. When the new procedures went forward for authorization, the team showed the Head of Operations and the refinery technologists the data they had gathered. This revealed that a particular stage in the process went into alarm for a variety of reasons on a large number of occasions, i.e. the operators, through carrying out PCDM, had discovered that the process was not very well controlled at that point. This prompted the technologists to make changes to the design of the plant, which reduced the frequency of process disturbances. This is a good example of how the bottom-up communication stimulated by PCDM can generate learning at the organisational level. This is not an isolated example, as data gathered by operators in the course of PCDM quite frequently guides technologists in the re-engineering of the plant.

*(4) The normalisation of a culture of continuous learning and improvement.*

When PCDM was introduced, many operators who had been doing their job for 20 years questioned whether they needed to change. However, now that "PCDM-ing everything" has become part of everyday experience in Company U, most employees accept that they should accommodate their own practice to the consensus view of best practice that is emerging from PCDM. It has created a culture of continuous improvement.

*(5) Spin-out into the Training Centre*

A further impact on the learning environment in Company U that needs to be mentioned is that the procedures resulting from PCDM serve as what one employee responsible for on-the-job training calls "a super-doooper training specification". That is, by making agreed best practice explicit, the procedure provided detailed guidelines for planning courses of instruction for (for example) new employees. This is an example of how the knowledge created by PCDM becomes part of organisational memory available to all, and is capable of generating benefits well beyond what was originally intended.

## **5.4 Case 3: Site exchanges**

As described in section 5.1, Company U operates in a competitive business environment. One of the ways in which it is seeking to learn as an organisation is by comparing itself with other chemical companies and other sites within the same parent company. An essential prerequisite for this kind of learning is to measure company performance against targets or benchmarks and to ensure that the results are widely known throughout the

organisation. This is done by various benchmarking procedures and by maintaining an awareness of the company's position in the 'league tables' by holding regular site meetings and beaming information at all employees through other communication channels. All employees are aware of the competitive business environment and where the company stands in comparison with the competition. Using Key Performance Indicators, specific company and plant targets are set for improving performance in order to close any gaps. The system of setting annual 'tasks and targets' for each employee is tied fairly closely to these company targets. In-company training courses are commissioned on the basis of learning needs identified in appraisal meetings which assess performance in tasks and targets. In this way, individual learning needs are articulated with the learning needs of the company as a whole.

Against this background, one major organisational learning initiative has been to learn as much as possible from another company that we will call X Corporation. This company has an outstanding safety record, and sells its expertise in health and safety practices to other companies. It has developed a philosophy and methodology for creating a safety culture, and it sells it to Company U.

For some time, Company U have been actively attempting to build the kind of safety culture which is believed to exist in the X Corporation. One way in which they are attempting to do this is by sending employees on visits to X Corporation plant. Their brief is to observe differences in the culture of the two sites, and to report back to their colleagues at Company U in the hope that the X Corporation culture will begin to be assimilated into the culture of Company U.

Another strategy is to send Company U employees on visits to other sites of the parent company throughout Europe. Typically, a group of four operators are sent from Company U to the other site. Their mission is to find 10 improvements in working practices to bring home, and to give 10 pieces of good advice to the site they are visiting. The visits are organised on a reciprocal basis, six months later Company U receiving a visit from the other site. The company organises about seven such exchanges each year. The visitor groups, both incoming and outgoing, make a final presentation to management at the site they are visiting, and report back formally when they return to their own company. Several of the lessons learned in this way have made significant changes to the production process at Company U, resulting in cost savings that have been calculated as more than £500,000 per year.

As one interviewee said:

" A lot of people have been on [fact finding visits to other sites] and now we tend to use a lot of things that they use, and people are far more eager these days to adopt other people's practices than they would have been in the past".

## 5.5 Conclusions

The three initiatives we have described in this report are not the only ways in which Company U is engaging in organisational learning. However, these ways of learning – The Systematic Approach, PCDM and Site Exchanges – collectively satisfy all the criteria of organisational learning defined by this project.

### **Criterion 1. Organisational work routines are being evaluated and improved**

This is occurring through all three initiatives, the Systematic Approach, PCDM and Site Visits. All three focus directly on work routines and how to improve them, and they all support learning as an organisation. Virtually all the company's work routines have been evaluated and improved through these activities.

### **Criterion 2. Formal and informal learning processes are being evaluated and improved**

The Systematic Approach aims to make learning in groups part of the organisation's culture, and in our interview data there is evidence that it has succeeded. The appointment of Systematic Approach facilitators ensures that this informal learning process is constantly being evaluated and reinforced. PCDM, originally designed as a way of revising procedures, is now being transformed into a way of developing competence – i.e. its potential as a way of learning has been evaluated and is being improved. Many methods of formal training in the company are also being evaluated and improved, but they tend focus on individual mastery and so fall outside the scope of this report.

### **Criterion 3. Transformations are occurring in the culture of the organisation**

Culture change is a major objective, especially building a culture of collaboration and good internal communication, and building a safety culture. There is evidence that the old 'operator culture' has changed to one in which workers are willing to abandon old practices and adopt what is collectively regarded as better practice. There has also been a change in the management culture, which is less top-down and more participatory in nature. Although there is some way to go before Company U achieves the safety culture found at X Corporation, they are making progress.

### **Criterion 4. Knowledge is being created within the organisation, at different levels (not only by the managers/scientists) and it is being shared within the organisation**

Both The Systematic Approach and PCDM, which are implemented primarily by operators, are generating knowledge about best practice in operating procedures. This has improved performance and has led to major improvements in plant design. There are effective strategies for sharing this knowledge throughout the organisation. Another

initiative, not mentioned above, is the incident reporting system. This collects information about accidents and near misses and places it in organisational memory on the intranet. The information is transformed into knowledge by being systematically analysed by specialists and widely discussed at plant level.

**Criterion 5. Learning from the environment is encouraged and systematically evaluated. The results are assimilated and accommodated to the company's objectives and local constraints and opportunities.**

Management are learning about the company's performance through extensive benchmarking, and visits to other sites enable operators to learn better practices from other companies. What is learned in this way is assimilated to the company's collective knowledge base by being fed into PCDM and periodic general site meetings.